

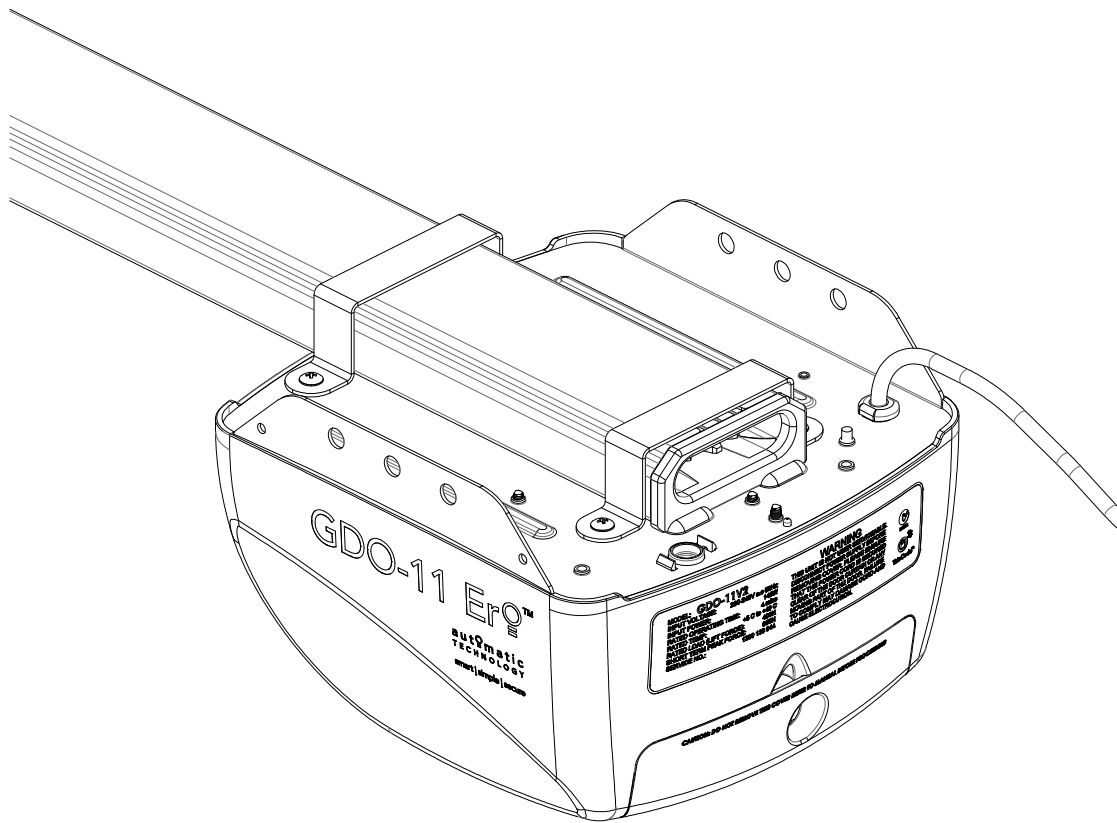

GDO-11v2 Ero™

Overhead Garage Door Opener



Featuring **TrioCode™** Technology

Technical Document

Installation Manual

v **1.00**

21 Feb 2012

English

Part # 13239 (Manual)

aut^omatic
TECHNOLOGY

smart | simple | secure



WARNING: It is vital for the safety of persons to follow all instructions. Failure to comply with the installation instructions and the safety warnings may result in serious personal injury and/or property damage.

Please save these instructions for future reference.

Automatic Technology (Australia) Pty Ltd to the extent that such may be lawfully excluded hereby expressly disclaims all conditions or warranties, statutory or otherwise which may be implied by laws as conditions or warranties of purchase of an Automatic Technology (Australia) Pty Ltd Overhead Door Opener. Automatic Technology (Australia) Pty Ltd hereby further expressly excludes all or any liability for any injury, damage, cost, expense or claim whatsoever suffered by any person as a result whether directly or indirectly from failure to install the Automatic Technology (Australia) Pty Ltd Overhead Door Opener in accordance with these installation instructions.



GDO-11v2 Ero™

Overhead Garage Door Opener

Important Safety Instructions	4		
Features	6		
Operating Controls	8		
Kit Contents	10		
Installation	11		
Knockdown C-Rail Assembly	11		
C-Rail Attachment	13		
Determine Door Type	14		
Mounting - Track Type Door	15	Accessories	25
Mounting - Spring Loaded Door	16	Safety Beam Installation	25
Mounting Door Bracket & Arms	17	Auxiliary output / Key switch	26
Programming the Opener	18	Battery Backup installation	26
Setting Travel Limits - Control Panel	18	SmartSolar™ Installation	28
Setting Travel Limits - Transmitter	19	Final Setup	29
Safety Obstruction Forces	20	Pet Mode Door Height	29
Safety Obstruction Force Test	20	Wall Mounted Transmitters	29
Adjusting Safety Obstruction Forces	21	Re-Initialising	29
Coding Transmitters	22	Default Settings & Specifications	30
Door	22	Parameters	31
Vacation Mode	22	Door Status Indicators	31
Auxiliary Out Put	22	Button Functions	31
Pet Mode	23	Troubleshooting Guide	32
Courtesy Light	23	Maintenance	33
Remotely Coding Transmitters	24	Parts Listing	34
Erasing Transmitter Codes	24	Warranty	35





Important Safety Instructions

WARNING: It is vital for the safety of persons to follow all instructions. Failure to comply with the following Safety instructions may result in serious personal injury and/or property damage.

CAUTION: If your garage has no pedestrian entrance door, an emergency access device should be installed. This accessory allows manual operation of the garage door from outside in case of power failure.

Automatic Technology **strongly** recommends **Safety Beams** are installed with the automatic opener ensuring additional safety and peace of mind.

DO NOT operate the opener unless the garage door is in full view and free from objects such as cars and children/people. Make sure that the door has finished moving before entering or leaving the garage.

DO NOT operate the opener when children/people are near the door. Children must be supervised at all times when the Ero™ is in use. **Serious personal injury** and/or property damage can result from failure to follow this warning.

DO NOT allow children to operate the Ero™. **Serious personal injury** and/or property damage can result from failure to follow this warning.

Regularly check to make sure that the **Safety Obstruction Force** is working correctly, and is **tested** and set as per **page 20 of this manual**. Failure to follow these instructions could result in **serious personal injury** and/or property damage. This test must be repeated at regular intervals and the necessary adjustments made as required.

A **Safety Beam** must be used if the closing force as measured on the bottom of the door is more than 400N (40kg).

DO NOT disengage the door opener to manual operation with children/people or any other objects including motor vehicles within the doorway while in the open position.

The door opener is not intended for use by young children or infirm persons without adequate supervision. Children should be supervised to ensure that they do not play with the remote transmitters or the opener.

Keep hands and loose clothing **clear** of the door and door opener at all times.



Important Safety Instructions

The unit should be installed so that it is protected from the elements. It should not be exposed to water or rain. It is not to be immersed in water or sprayed directly by a hose or other device.

The garage door must be **well balanced**. Sticking or binding doors must be repaired by a qualified garage door installer prior to installation of the opener.

Frequently examine the installation, in particular cables, springs and mountings for signs of wear, damage or imbalance. **DO NOT** use if repair or adjustment is needed since a fault in the installation or an incorrectly balanced door may cause injury. **DO NOT** attempt to repair the door yourself as hardware is under extreme tension.

Remove or disengage all garage door locks and mechanisms prior to installation of the opener.

Connect the opener to a properly **earthed** general purpose 240V mains power outlet installed by a qualified electrical contractor.

Disconnect the power cord from mains power before making any repairs or removing covers. Only **experienced** service personnel should remove covers from the opener.

In order for the Ero™ to **sense** an object obstructing the door way, some **force** must be exerted on the object. As a result the object, door and/or person may suffer **damage or injury**.

If the power supply cord is damaged, it **must** be replaced by an Automatic Technology service agent or suitably qualified person.

Make sure that the door is fully open before driving in or out of the garage and fully closed before leaving the driveway.

Make sure that remote controls are kept out of reach of children.

Install the (optional) wall switch or (optional) wall mounted transmitter in a location where the garage door is visible, but out of the reach of children at a height of at least 1.8 metres from the floor.





Features

Thank you for purchasing the Automatic Technology **GDO-11v2 Ero™** Overhead Garage Door Opener. Designed to suit sectional overhead and one piece tilt up doors, the components and materials used ensure this opener will provide years of smart, simple and secure operation. Listed below are some of the many features:

Operation

To open or close the door simply press a button on a TrioCode™ handheld transmitter, or optional wall switch for two seconds. During open and close cycles the door can be stopped by pressing the button again. The next actuation will move the door in the opposite direction.

TrioCode™ Code Hopping Technology

Every time a TrioCode™ transmitter is used a new security code is randomly generated from over 4.29 billion possibilities. This greatly enhances the security of the system and makes "code grabbing" a thing of the past

These transmitters also overcome interference issues by simultaneously sending a signal over three different frequencies. Even if two of the three signals are jammed, the system will still work.

S-ALPS (Semi Automatic Limits Positioning System)

The S-ALPS system does away with manual adjustment of the door's limits position using mechanical parts, such as cams and microswitches. During installation the handheld transmitter can be programmed to set the limits positions.

ISS (Intelligent Safety Obstruction System)

While the door is performing a close cycle, should it hit an obstacle or be restricted in some manner, it will automatically reverse. The amount of force the door should encounter before reversing is automatically adjusted by the doors control system during the initial installation of the automatic door opener. The door will also stop if restricted whilst opening. The Safety Obstruction Force should be checked monthly.

Auto courtesy light

The courtesy light comes on automatically for three minutes whenever the door is activated. The light can also be operated independently of the door by coding a dedicated button on a transmitter.





SmartSolar™ and Battery Backup Compatibility (optional)

The opener can be fitted with a SmartSolar™ or Battery Backup kit for operation in the event of a power outage, or where mains power access is not available.

NOTE: If the door is the only entrance to the garage, and a battery backup kit is not fitted, a keyed cable release should be fitted externally to the garage.

Vacation mode

A hand held transmitter can be programmed to lock and unlock all other transmitters that have been programmed into the openers' memory. The vacation mode can be used when the door is left idle for long periods of time.

Pet/Pedestrian mode

The transmitter can be programmed to open the door to an adjustable partial height so that the family pet can enter and exit the garage at any time. You may also wish to open the door to a height suitable only for pedestrian access.

Safety Beam (optional)

The opener has an input to connect a Safety Beam for extra safety.

Manual Operation

The opener is equipped with a unique manual disengaging device. If the power to the opener is disrupted, the door can be put into manual mode by pulling down on the string handle on an angle towards the door. This allows for manual operation of the door. To re-engage the opener, pull the string handle away from the door. Do not disengage while the door is in the open position.





Operating Controls

- 01 Terminal Block (Left to Right).**
 - V+ is used to power wireless Safety Beam, external receiver etc.
 - SB1 first Safety Beam input.
 - 0V for Safety Beam
 - SB2 second Safety Beam input.
 - 0V for Safety Beam
 - AUX/ O/S/C can either be used to control another device (such as alarm system etc) via the openers remote control or a wired switch (momentary contact) can be connected to this terminal to open, stop or close the door.
- 02 Coding Led** (red) light flashes when a code is being stored or when a transmitter button is pressed.
- 03 DOOR CODE** button is used for storing or erasing transmitter buttons for door operation
- 04 Door Status Led** (Yellow)
- 05 SET** button (Orange) is used during the installation phase together with the PLUS (+) and MINUS (-) buttons to set the door limit positions. The SET button is also used to re-initialize the Opener.
- 06 OPERATE** button (Yellow) is used during installation to test the open, stop and close cycles for the opener. The opener has to be initialised by the SET button to make the OPERATE button operable.
- 07 FORCE MARGIN SET** Button: The obstruction force margin is set automatically during installation. The margin can be adjusted manually using the FORCE MARGIN SET button (White). Holding the FORCE MARGIN SET button and pressing PLUS (+) or MINUS (-) buttons will increase or decrease the amount of force. The FORCE MARGIN SET should only be used if environmental factors (wind, etc.) affect the door's operation.
- 08 Open Limit Led** (green) the LED is very helpful during installation. It illuminates and flashes when the door is opening and remains steady on when the open limit position has been reached.
- 09 PLUS (+)** button (green) is used during installation to help set the open limit position. Pressing and holding this button will move the door in the open direction, releasing stops the door.
NOTE: The safety obstruction detection is inoperable when the PLUS (+) button is used to move door.
- 10 Close Limit Led** (red) the LED is very helpful during installation. It illuminates and flashes when the door is closing and remains steady on when the close limit position has been reached.
- 11 MINUS (-)** button (red) is used during installation to help set the close limit position. Pressing and holding this button will move the door in the close direction. Movement stops when the button is released.
NOTE: The safety obstruction detection is inoperable when the MINUS (-) button is used to move door.
- 12 Datum Adjust Screw** is used during limits set up to indicate the mid point of the door's travel.
- 13 10A Fuse**
- 14 Prog Input** is used to connect the Automatic Technology Handheld Programmer "PG-3" for editing control and receiver functions, accessing diagnostic tools, and activating special features and operating modes.
- 15 JP1 Solar Connector** the shunt must be fitted for solar operation.
- 16 Courtesy Light** 15 watts 24 volts festoon type globe is used for courtesy light.
- 17 SBCO2 J4 Standby Battery Charger Connector** the shunt must be fitted if battery charger is not connected.



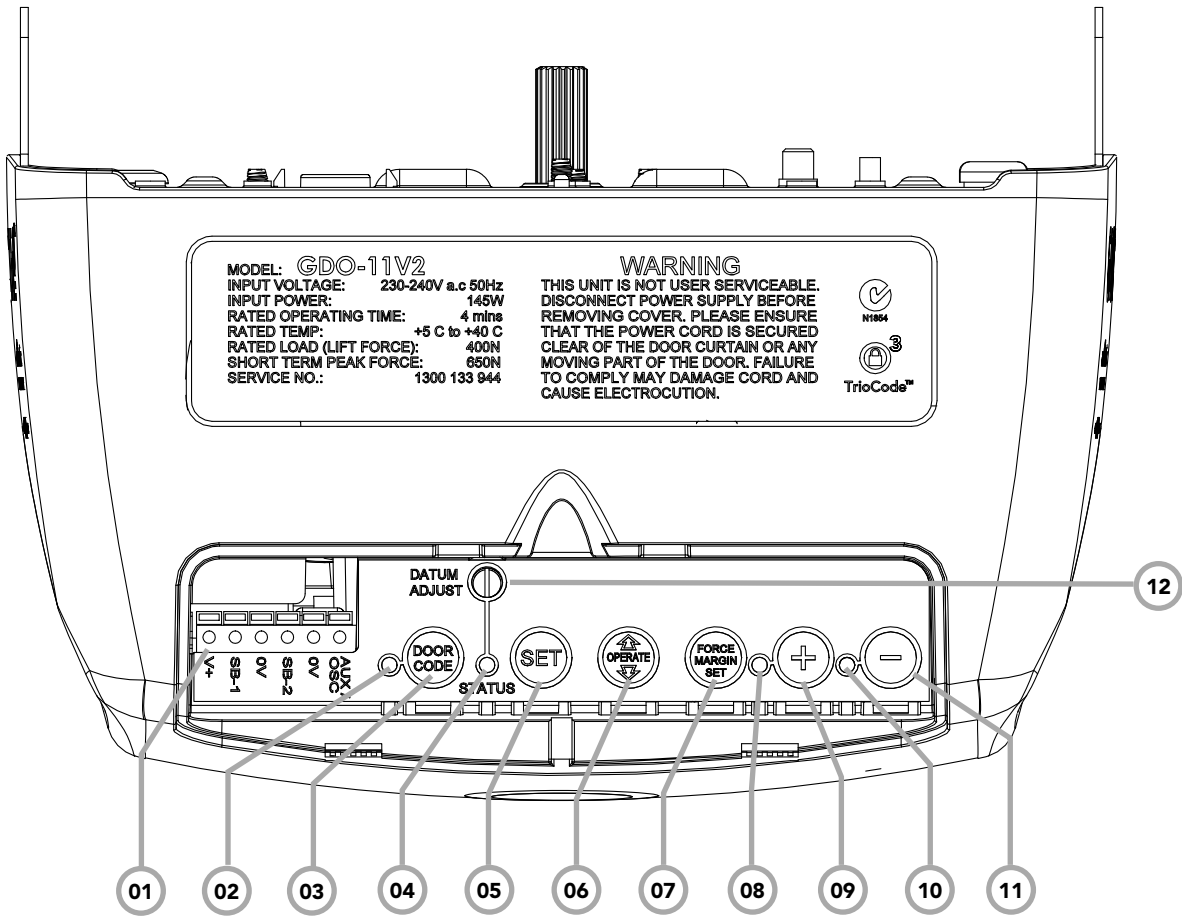
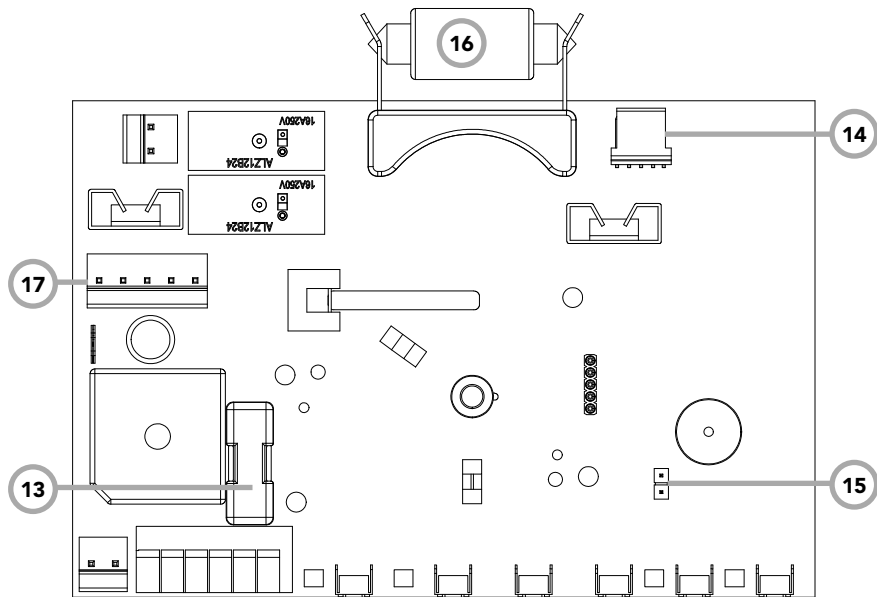

fig 01





Kit Contents

fig 02

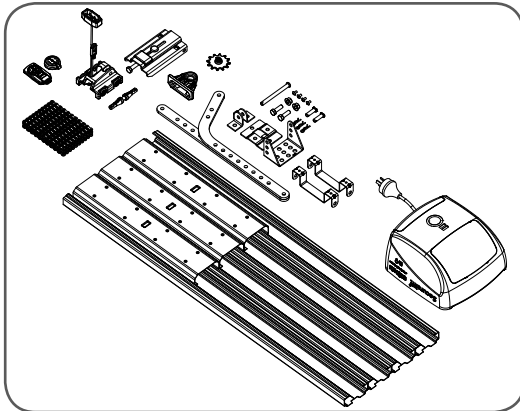

GDO-11v2 Multipiece C Rail And Accessory

- 1 x GDO-11v2 Ero™ drive unit (Fig. 2)
- 1 x TrioCode™ Transmitter pack (Fig. 2)
(Pack includes 1x four button keyring transmitter and 1x two button keyring transmitter with batteries)
- 2 x Door attachment arms (Fig. 2)
- 1 x Accessory and hardware pack (Fig. 2)
- 1 x Chain (Fig. 2)
- 1 x C rail track pack (Fig. 2)
(Pack includes three C rail sleeves and four C rail tracks)
- 1 x Shuttle assembly (Fig. 2)
- 1 x Installation Manual

OR

fig 03

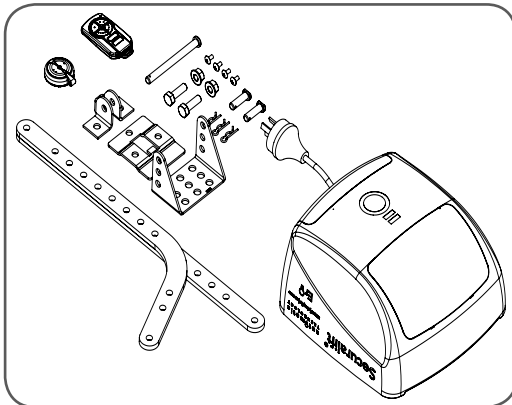

Power Head And Accessory pack

- 1 x GDO-11v2 Ero™ drive unit (Fig. 3)
- 1 x TrioCode™ Transmitter pack (Fig. 3)
(Pack includes 1x four button keyring transmitter and 1x two button keyring transmitter with batteries)
- 2 x Door attachment arms (Fig. 3)
- 1 x Accessory and hardware pack (Fig. 3)
- 1 x Installation Manual

PLUS

fig 04

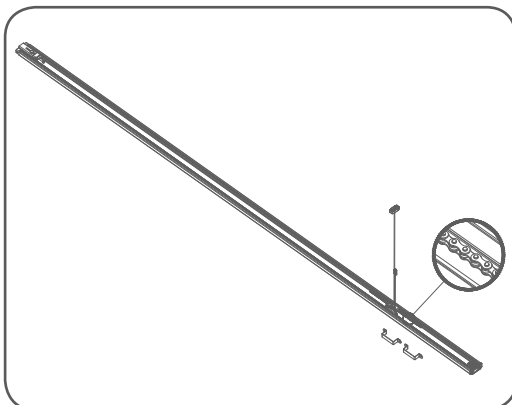

Pre-Assembled Single Piece C-Rail

NOTE: The chain in the single piece C-Rail has been tensioned by the factory.

IMPORTANT NOTE: If modification to the track length is required, adjustment must be made to the drive end side only.





Knockdown C-Rail Assembly

Step 1 - Knockdown C-Rail Assembly

Note: If your opener came with a one piece track, proceed to Assembly step 2, page 13.

- Place track pieces on flat surface for assembly. All the track sections are interchangeable.
- Slide sleeve onto the track section (**Fig. 05**). Connect track by sliding sleeve onto next track section. Tap track assembly on piece of wood until track sections are flush. Repeat with remaining track sections.
- Remove chain from package and lay chain out on floor (do not allow chain to twist).
- Loop the chain onto the pulley of tension chain assembly. Slide the tension chain assembly with chain into the track (**Fig. 06**).
- Slide shuttle assembly into (opener end) the track assembly. Be sure to insert shuttle assembly with hole side toward the door as shown with arrow in (**Fig. 07**). Push the sprocket support into (opener end) of the track.
- Feed the chain through the shuttle assembly then through the sprocket support. Loop around the sprocket then feed back through the sprocket support and shuttle assembly. Join to chain index with chain links (supplied) (**Fig. 07**).

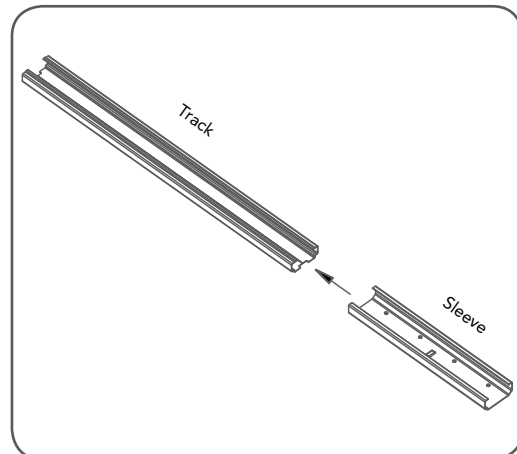

fig 05

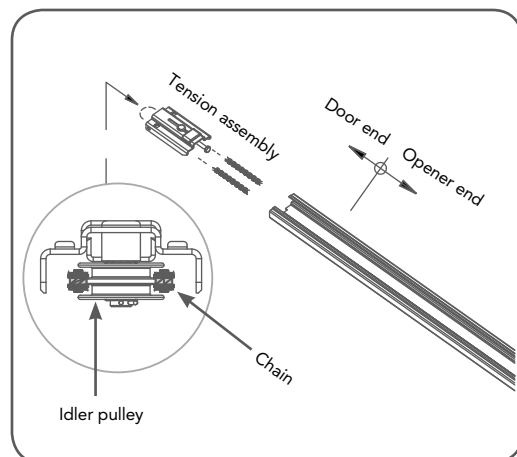

fig 06

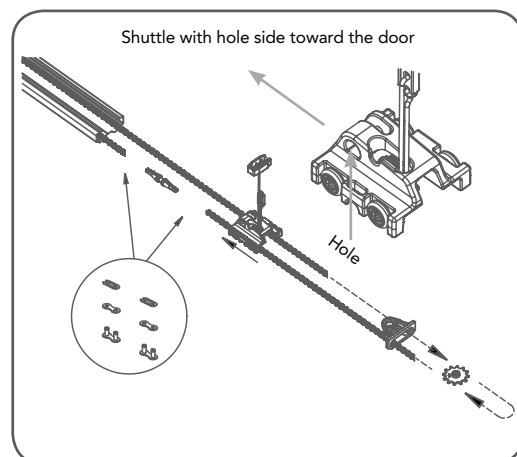

fig 07





Knockdown C-Rail Assembly

fig 08

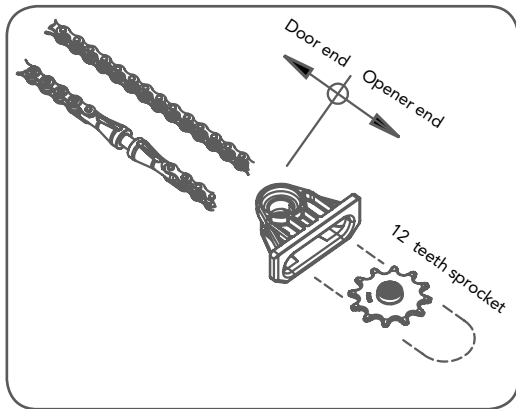

Note: Use the 12 teeth sprocket with GDO-11v2 Ero™.

- h. Engage the shuttle with the chain index and move shuttle assembly to the centre of track. Make sure the chain is engaged into the sprocket and also wrapped around the centre of the pulley.
- i. Use a spring scale to measure required force to pull the shuttle, adjust 1/2" tension hex bolt (**Fig. 09**) to tension the chain.
- j. Move the shuttle back to the centre of the track to re-test the force with spring scale (**Fig. 10**).
- k. Continue to adjust the tension hex bolt until a force of 8kg to 8.5 Kg is achieved.

fig 09

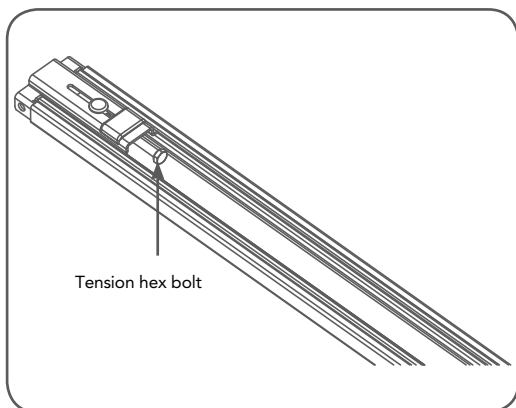
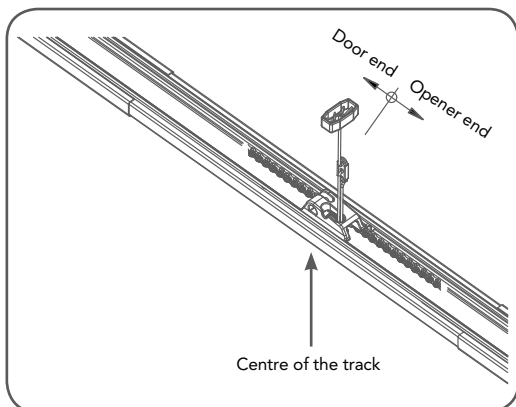

fig 10





C-Rail Attachment

Step 2 - Secure C-Rail to Drive Unit

- Locate and insert the shaft of drive unit into the C-Rail's sprocket (**Fig. 11**).
- Fix the two track brackets with four screws supplied in accessory pack (**Fig. 12**).

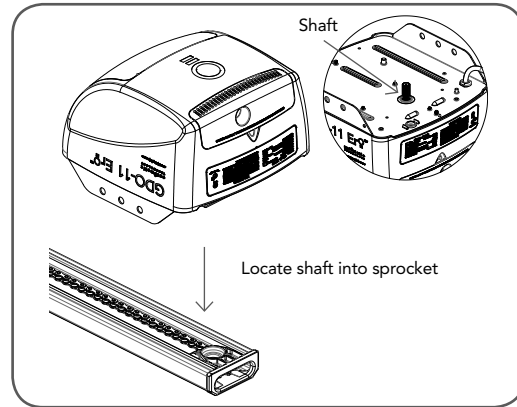

fig 11

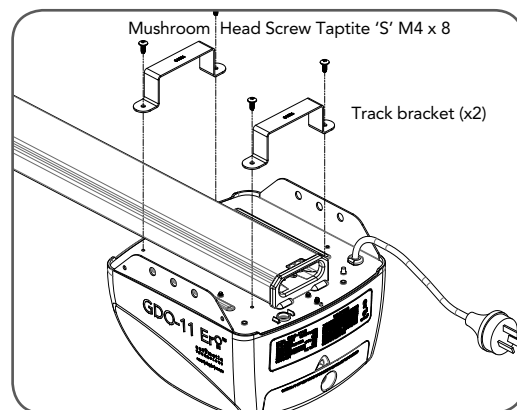

fig 12





Determine the Door Type

fig 13

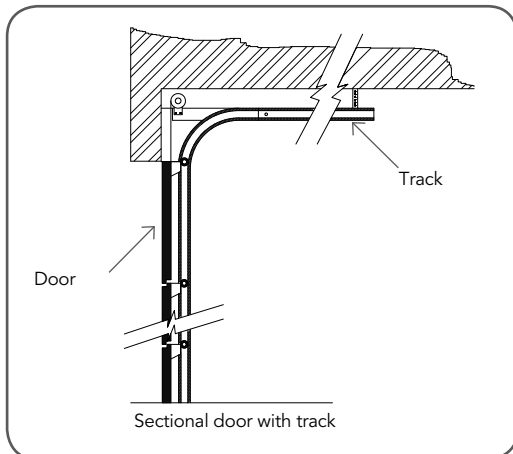

Step 3 - Determine Door Type

Determine which type of garage door you have as illustrated below. (Fig. 13 to 15).

For a sectional (panel) door on tracks (Fig. 13) proceed with the installation from Step 4.

fig 14

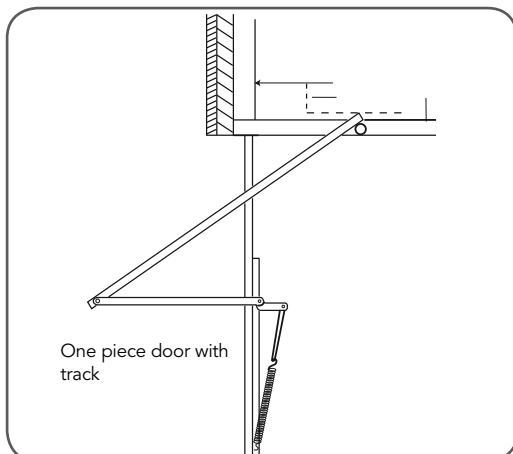

For a one-piece door on tracks (Fig. 14) proceed with the installation from Step 4.

fig 15

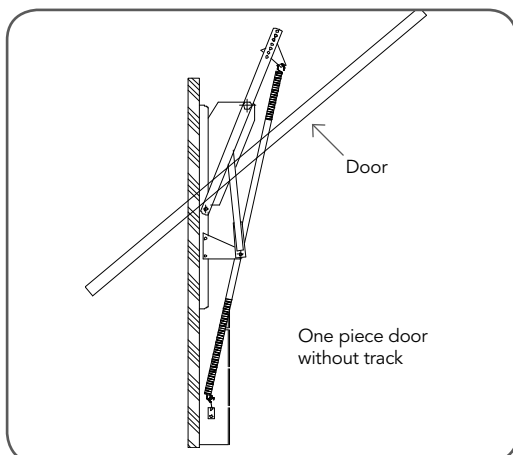

For a one-piece door without tracks (on springs) (Fig. 15) proceed with the installation from Step 8.



Mounting On a Track Type Door



WARNING: The opener must be securely fastened to structural supports, otherwise opener failure may ensue causing serious personal injury and/or property damage.

Step 4 - Determine Bracket Position

- Open the door and find the highest point of travel of the top door panel.
- Using a level, transfer this height to the wall above the door (**Fig. 16**) and mark a line 60mm above it.
- Determine the centre point on the wall above and on top of the door. Draw two lines extending 21.5mm from each side of the centre point. (**Fig. 17**)

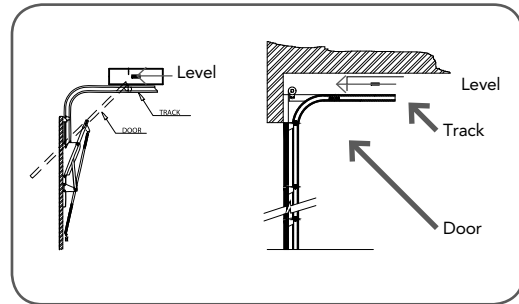

fig 16

Step 5 - Mounting The Wall Bracket

- Centre the bracket over the intersection of these two lines. Mark centres for at least two holes (**Fig. 17**) and ensure it is into a solid mounting point.
- Drill holes into the wall with an appropriate bit.
- Secure to the wall using:
 - IF CONCRETE OR BRICK - 8mm (5/6") loxins/dynabolts.
 - IF TIMBER - wood screw #20 or similar (min. 50mm).

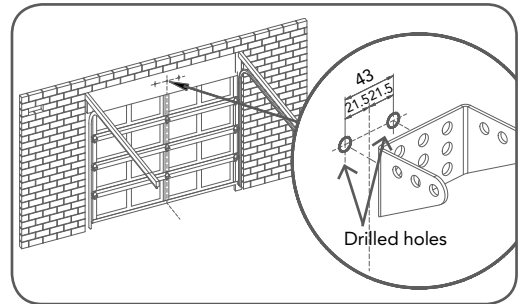

fig 17



WARNING: Make sure concrete, brick wall or timber lintels are solid and sound so as to form a secure mounting platform.

Step 6 - Attach The C-Rail To The Wall Bracket

- Attach the C-Rail assembly to the wall bracket with the 90mm long clevis pin and secure with the supplied snap pin. (**Fig. 18**)
- Leave the drive unit in its packing box for protection during installation.

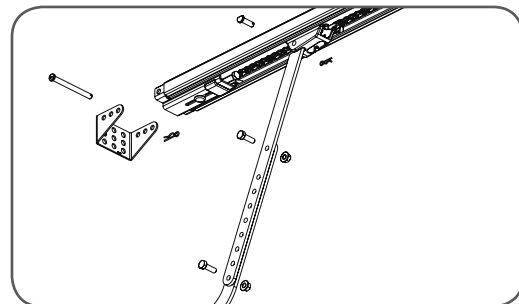

fig 18

Step 7 - Secure The Drive Unit To The Ceiling

- Raise the drive unit from the packing box and support it in the horizontal position with a step ladder or with a similar rigid object.
- Open the garage door. Rest the opener on the open door and use a scrap piece of wood to bring it to horizontal level.
- Line up the track perpendicular to the wall.
- Secure the perforated angle (not supplied) to the ceiling above where drive unit's mounting holes will be once fully installed. A representative mounting is shown (**Fig. 19**)
- Connect the drive unit to the ceiling mounted perforated angle with M8x20mm screws and nuts. Strips should not extend more than 18mm below centre of drive unit mounting holes.

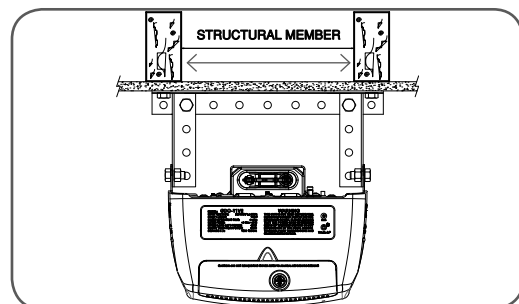

fig 19

Go to Step 12 on page 17.





Mounting on a Spring Loaded Type Door

fig 20

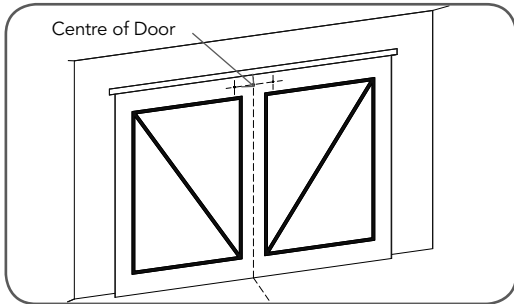

WARNING: The opener must be securely fastened to structural supports, otherwise opener failure may ensue causing serious personal injury and/or property damage.

Step 8 - Determine the Door's Centre

- Find the centre of the door and mark this location both above the door and on top of the door.
- Draw two lines 21.5mm either side of this (**Fig. 20**).

Step 9 - Prepositioning the Opener

- Raise the door to open position.
- Rest the opener on the top edge of the door with end of the C-Rail against the wall (**Fig. 21**).
- Support the Drive unit level with the lowest point of the open door (**Fig. 21**).

NOTE: Do not slide C-Rail along the face of the door.

fig 21

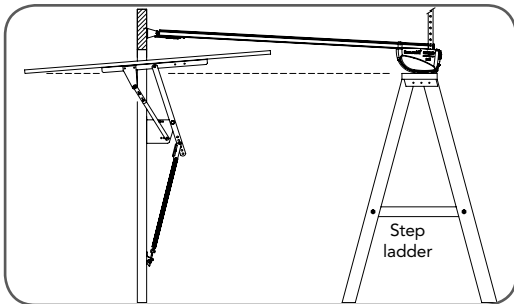

Step 10 - Mounting the C-Rail

- Close the door slowly. The C-Rail will be elevated by the top edge of the door as it moves.
- Stop the door when it is at its highest point of travel. Allow 25mm additional height for clearance between the door and the track (**Fig. 22**).
- Support the C-Rail in this position and close the door.
- The height determined in Step 10 (b) will be the height at which to mount the wall bracket.
- Centre the bracket along the line determined in Step 8.
- Using the bracket as a template, mark a minimum of two holes and drill with appropriate size bit. For a more secure fitting, the wall bracket can be anchored using more than two holes.
- Secure the bracket to the wall using:
IF CONCRETE OR BRICK - 8mm (5/8") loxins/dynabolts.
IF TIMBER - wood screw #20 or similar (min. 50mm)
- Attach the bracket and C-Rail with supplied pins (**Fig. 18**).

fig 22

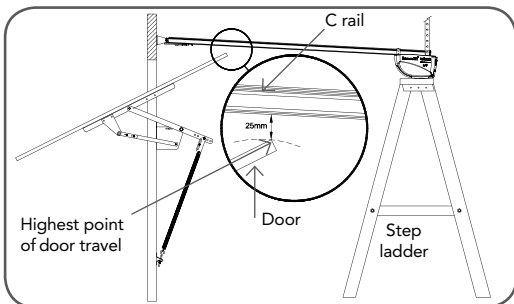

WARNING: Make sure concrete, brick wall or timber lintels are solid and sound so as to form a secure mounting platform.

Step 11 - Secure the Drive unit to the Ceiling

- Secure the perforated angle (not supplied) to the ceiling above where drive unit's mounting holes will be. See (**Fig.19**) for a representative mounting.
- Connect the drive unit to the ceiling mounted perforated angle with M8x20mm screws and nuts. Strips should not extend more than 18mm below centre of drive unit mounting holes (**Fig. 19**).

fig 23

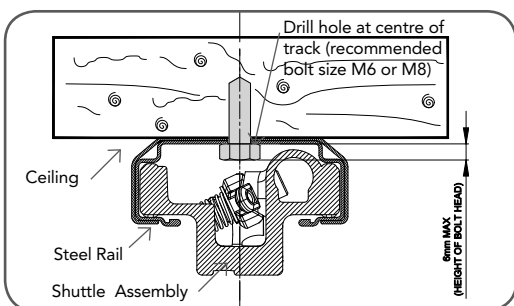

Step 11.1 - Alternative Mounting Option

The opener can be fastened to the roof by driving a bolt through the C-Rail into a structural timber support. The





Mounting Door Bracket & Arms

Step 12 - Mounting Door Bracket

The door bracket comes in two parts. The bottom plate with two mounting holes is used on its own for one piece doors. For sectional doors, the top plate is placed over the bottom plate and is fixed with four (4) screws (**Fig. 24**).

- Mount the door bracket, or bracket assembly, on the door's centre line one-third down the top panel (**Fig. 24**) using M6 or equivalent screws (not supplied),
- STEEL DOORS ONLY: Bracket can be welded in place.



WARNING: Door damage may occur if the bracket is installed on a panel with insufficient strength. The opener's warranty does not cover damage caused to the door and/or door panels. If in doubt about the door's strength, reinforcement may be added to the door's frame where necessary.

Step 13 - Attaching the Arms For Sectional And One Piece Doors With Track:

- Assemble the bent arm (connecting to the door) to the right side of the straight arm (connecting to the shuttle) with bolts and nuts supplied in the accessory pack (**Fig. 25**). Always use both bent and straight arms.
- Connect the assembled arm to the bracket and the disengaged trolley with clevis and snap pins. The angle "A" must be more than 10° (**Fig. 26**).



WARNING: Connecting the bent arm the other way around may damage the door. The straight arm should not protrude beyond the heel of the bent arm.

For One Piece Doors Without Track

- Assemble the bent and straight arms as shown in **Fig. 27** with bolts and nuts supplied in the accessory pack. Always use both the bent and straight arms.
- Connect the assembled arm to the bracket and the disengaged trolley with clevis and snap pins.
- If installing on a door with a bad wave action, lengthening the arm will assist in reducing this effect.



IMPORTANT NOTE: Adjust the length of the cord so that its toggle is no more than 1.8m from the ground.

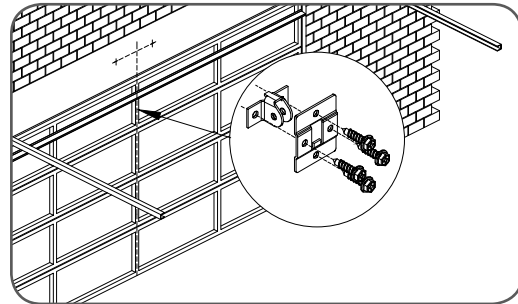

fig 24

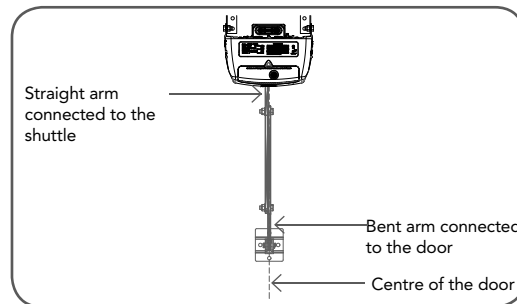

fig 25

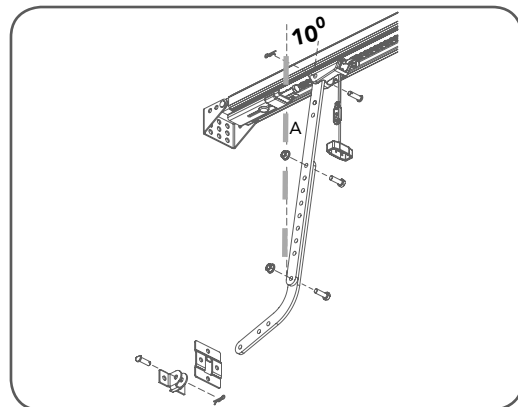

fig 26

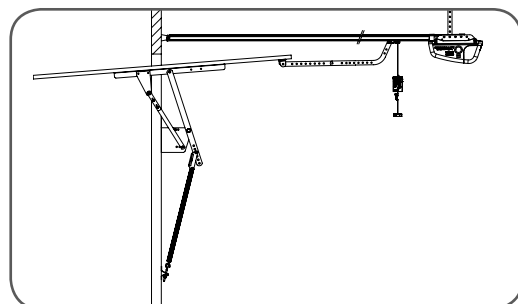

fig 27





Programming The Opener

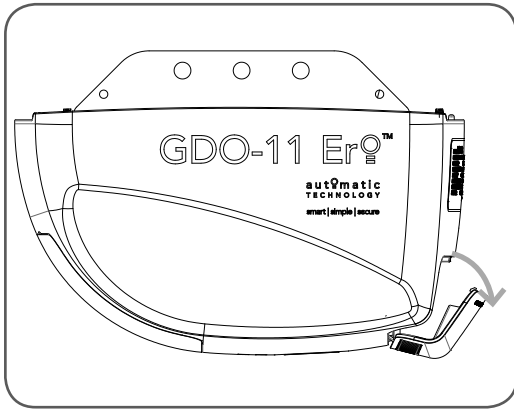

fig 28

Setting Limits - Via Control Panel



NOTE: If the Safety Beams are to be used they must be installed before setting the travel limits.

Step 14.1 - Remove Controls Cover

- Swing open the controls cover to gain the access to the controls panel (Fig. 28) and swing back into its position when setup is completed.

Step 14.2 - Connect Power to the Drive unit

Plug the power cord into a mains point and switch power on. The red CLOSE LIMIT LED will be flashing.



WARNING: The safety obstruction detection system is inoperable while MINUS (-) and PLUS (+) drive buttons are being used and travel limits are not set.

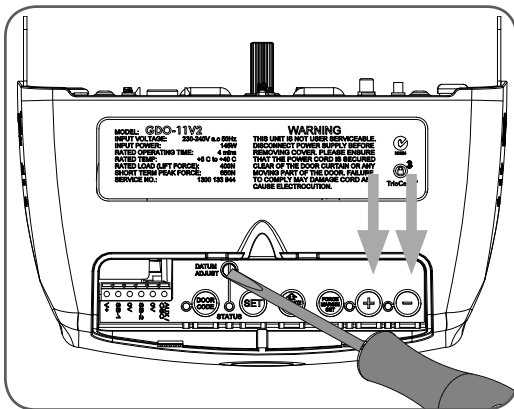

fig 29

Step 14.3 - Set the Datum Position

- Press and hold the MINUS (-) or PLUS (+) buttons to move the door to the halfway position. Ensure that the door, shuttle and chain index are engaged.
- Using a small screwdriver, turn the DATUM ADJUST screw until the STATUS LED comes on (Fig 29).

NOTE: If the STATUS LED is already illuminated when the door is halfway up, turn the DATUM ADJUST screw until the light goes off, then turn back one notch to illuminate again.

Step 14.4 - Set the Limits Positions

- Press and hold the MINUS (-) button until the door reaches the desired close limit position. Single presses will inch the door closed (Fig 30).
- Press the LIMIT SET button to store the close position into memory (Fig. 30).
- Press and hold the PLUS (+) button until the door reaches the desired open limit position. Single presses will inch the door open (Fig. 30).



IMPORTANT WARNING: The door will automatically close, open and close again **once Step 14.4(d) is performed**. Ensure that no persons or objects are in the door's path.

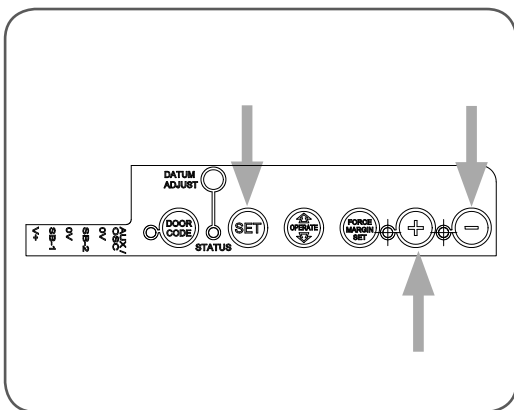

fig 30

- Press the SET button to store the close position into memory (Fig. 30).
- The door will now automatically close and open to calculate the safety obstruction settings. After this, the opener can be operated with the OPERATE button.

Step 14.5 - Resetting the Door Limit Positions

Limit positions can be deleted by the following steps:

- Press and hold the MINUS (-) button for six (6) seconds until you hear three beeps and the CLOSE LIMIT LED starts to flash.
- Release the CLOSE button.
- Repeat Steps 14.1 to 14.4 to set new travel limit positions.





Programming The Opener

Setting Limits - Via Transmitter

The GDO-11v2 Ero™ has the unique ability to set travel limits using the transmitter, allowing the installer to move around the garage and door to better assess the desired close and open limit positions.

Step 15.1 - Power Up and Set the Datum

- Follow Steps 14.1 to 14.3 as outlined overleaf.
Observe all warnings!

Step 15.2 - Code a Transmitter for Limit Setting

- Press and hold the DOOR CODE button (**Fig. 31**).
- Press Button 1 on the transmitter for two seconds (**Fig. 32**). Release and pause for two seconds. Press the same button again on the transmitter for two seconds.
- Release the DOOR CODE button.

Step 15.3 - Setting Limits via Transmitter

- Press and hold Button 4 on the transmitter to close the door. When the door is approx. 2 cm from the ground, release button 4.
- A brief press of Button 4 will allow you to “inch” the door closed. Keep doing this until the door reaches the desired close limit position.
- If the door is closed too far, press Button 1 to “inch” the door towards open.
- When happy with the close limit position, press Button 2 to store this in memory.
- Press Button 1 to open the door. When approx. 2 cm from the desired open position, release button 1.
- A brief press of Button 1 will allow you to “inch” the door open. Keep doing this until the door reaches the desired open limit position.
- If the door is opened too far, press Button 4 to “inch” the door towards close.



IMPORTANT WARNING: The door will automatically close, open and close again **once Step 15.3 (h) is performed**. Ensure that no persons or objects are in the door’s path.

- When happy with the open limit position, press Button 2 on the transmitter to store into memory.
- The door will now automatically close, open and close to calculate the safety obstruction settings. After this, the opener can be operated with the OPERATE button.

Step 15.4 - Resetting the Door Limit Positions

Limit positions can be deleted by the following steps:

- Follow Steps 14.5 (a) and (b), as outlined overleaf.
- Repeat Steps 15.1 and 15.3 to set new travel limit positions.
- There is no need to re-code the transmitter (Step 15.2) upon resetting travel limits. The transmitter will still be stored in memory.

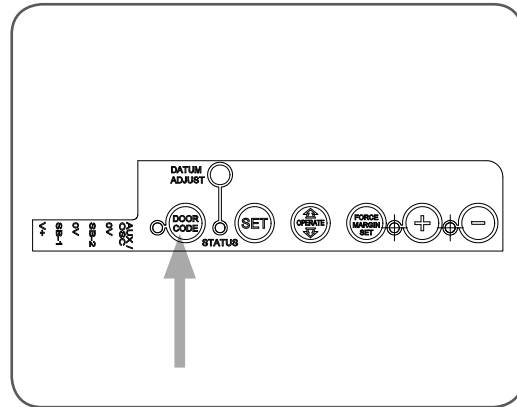

fig 31

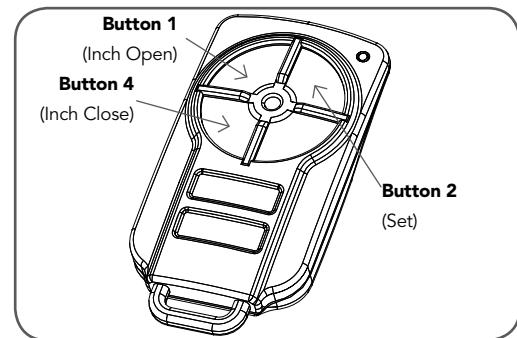

fig 32





Safety Obstruction Forces

fig 33

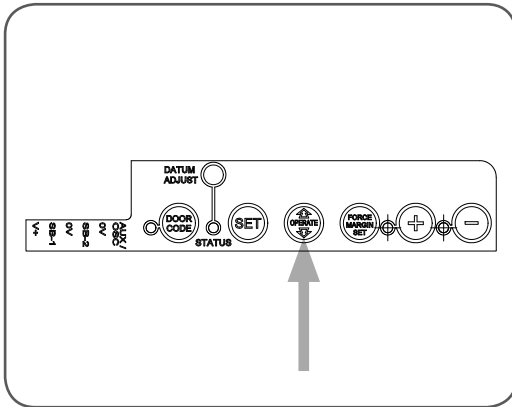

Safety Obstruction Force Test



WARNING! Take care when testing or adjusting the Safety Obstruction Force. Excessive force may cause **SERIOUS PERSONAL INJURY** and/or **PROPERTY DAMAGE**



WARNING! FOR **ADDITIONAL ENTRAPMENT** protection we **STRONGLY** recommend the fitting of a Safety Beam (SB). In most countries Safety Beams are mandatory on all garage doors fitted with automatic openers. For a small additional outlay Automatic Technology recommends that Safety Beam be installed with the automatic opener ensuring additional safety and peace of mind.

fig 34

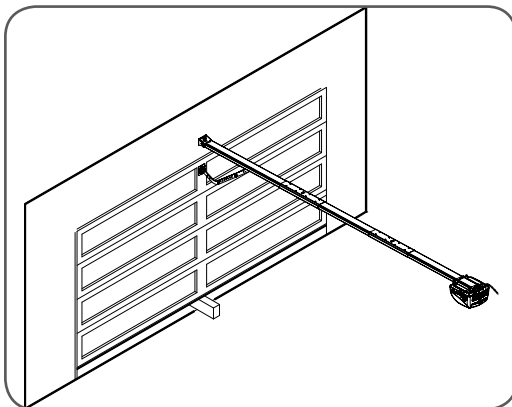

WARNING: Safety Beam must be installed if the closing force at the bottom edge of the door exceeds 400N (40kg force)

Step 16.1 - Testing Close Cycle

- Press the OPERATE button to open the door (**Fig. 33**).
- Place a piece of timber approximately 40mm high on the floor directly under the door (**Fig. 34**).
- Press the OPERATE button to close door. The door should strike the object and start to re-open.

Step 16.2 - Testing Open Cycle

- Press the OPERATE button to close the door (**Fig. 33**).
- Press again to open the door. When the door reaches the half open point, grab the bottom rail of the door firmly and the door should stop.
- If the door does not reverse readily when closing, or stop when opening, the force may be excessive and need adjusting, refer below.



DANGER! If the door fails these tests, put the opener into manual mode, only operate the door by hand and call for service.



Safety Obstruction Forces

Adjusting Safety Obstruction Force

The Safety Obstruction Force is calculated automatically during setup. Adjusting this is normally only necessitated by environmental conditions such as windy or dusty areas, and areas with extreme temperature changes.



WARNING: Safety Beams must be installed if the closing force at the bottom edge of the door exceeds 400N (40kg force)

Step 17.1 - To Increase Force Pressure

- Hold down FORCE MARGIN SET button (Fig. 35)
- While holding the FORCE MARGIN SET button, press the PLUS (+) button. Each press increases the force margin (Fig. 35).
- The OPEN LIMIT LED will flash each time the PLUS (+) button is pressed to indicate a force increase.
- If the OPEN LIMIT LED is on continuously when pressing the PLUS (+) button, this indicates that the maximum setting has been reached.
- Test the force again as per Steps 16.1 and 16.2

Step 17.2 - To Decrease Force Pressure

- Hold down FORCE MARGIN SET button (Fig. 35)
- While holding the FORCE MARGIN SET button, press the MINUS (-) button. Each press decreases the force margin (Fig. 35).
- The CLOSE LIMIT LED will flash each time the MINUS (-) button is pressed to indicate a force decrease
- If the CLOSE LIMIT LED is on continuously when pressing the MINUS (-) button, this indicates that the minimum setting has been reached.
- Test the force again as per Steps 16.1 and 16.2

Step 17.3 - To Recall Factory Set Force

- While holding down the FORCE MARGIN SET button, press the SET button for two (2) seconds. (Fig. 36)
- Release both buttons. The default setting should now be recalled.

Step 17.4 - To Recalculate Force Margins

- Press and hold the SET Button for two (2) seconds, the beeper will sound once (Fig. 37).
- The door will start to move and re-calculate force margins. The door can move between the open and close limit positions up to four (4) times (depending on the position of the door and the power up condition).
- A single beep will be heard once the process is complete.
- Test the force again as per Steps 16.1 and 16.2.

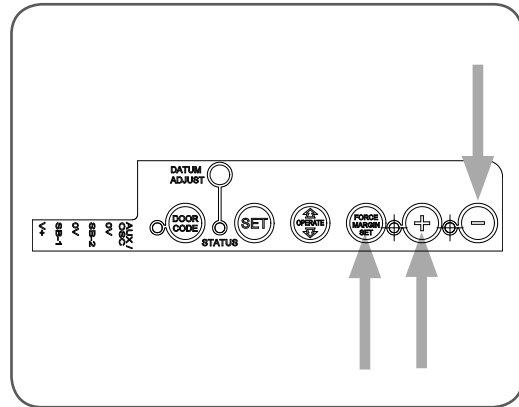

fig 35

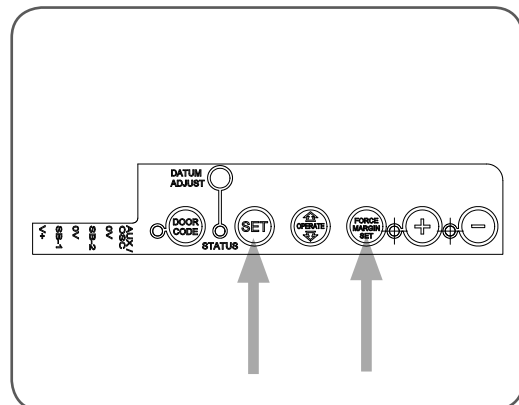

fig 36

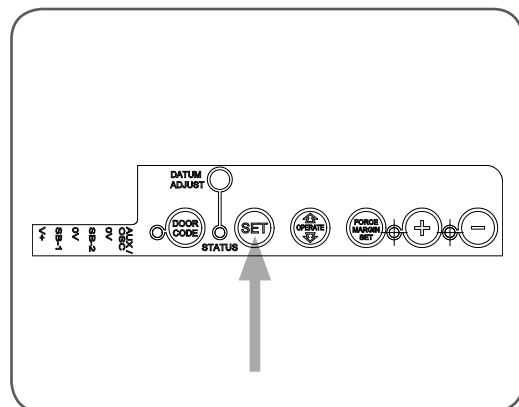

fig 37





Coding Transmitters

fig 38

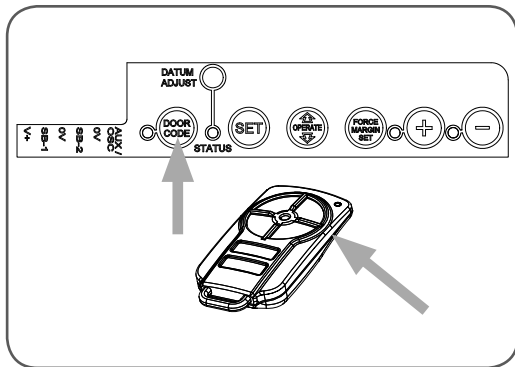

Step 18.1 - Code a Transmitter Button for Door Operation

- Press and hold the DOOR CODE button (**Fig. 38**).
- Press one of the four buttons on the transmitter for two (2) seconds, pause for two (2) seconds, then press the same button again for two (2) seconds.
- Release the DOOR CODE BUTTON.
- Press the transmitter button to test.

Step 18.2 - Code a Transmitter Button to Enable Vacation mode

The opener can be programmed into a "Vacation Mode" where the opener will not respond to any transmitter except the button of the transmitter that was programmed for vacation mode.

- Briefly press the DOOR CODE button once, then press it again and hold (will beep two times on second press (**Fig. 39**)).
- Press one of the four (4) buttons on the transmitter for two (2) seconds, pause for two (2) seconds, then press the same button again for two (2) seconds.
- Release DOOR CODE button.
- Press and hold the transmitter button for six (6) seconds to set Vacation Mode. The door code LED will stay lit while Vacation Mode is active.
- To reset Vacation Mode, press the same button for two seconds.

fig 39

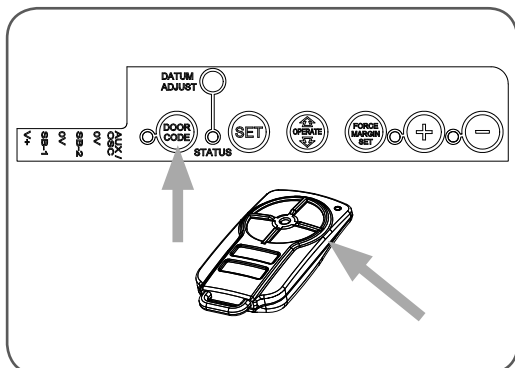

Step 18.3 - Code a Transmitter Button to Enable AUX OUTPUT

- Briefly press the DOOR CODE button two (2) times, then press it again and hold (will beep three times on third press (**Fig. 40**)).
- Press one of the four buttons on the transmitter for two (2) seconds, pause for two (2) seconds, then press the same button again for two (2) second.
- Release the DOOR CODE button.
- Press the transmitter button to test.

fig 40

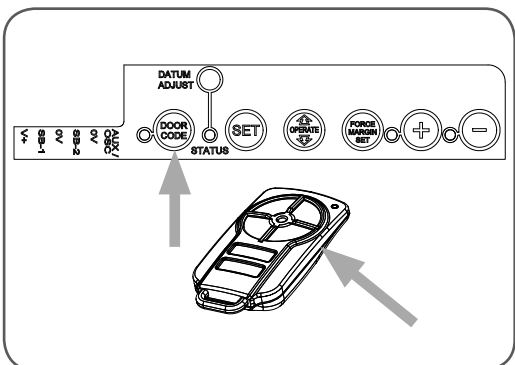



Coding Transmitters

Step 18.4 - Code a Transmitter Button for Pet (Pedestrian) Mode

- Briefly press the DOOR CODE button three times, then press it again and hold (will beep four times on fourth press (**Fig. 41**)).
- Press one of the four buttons on the transmitter for two (2) seconds, pause for two (2) seconds, then press the same button again for two (2) seconds.
- Release the DOOR CODE button.
- Press the transmitter button to test.
- To change the default pet (pedestrian) door opening position, refer Step 25.

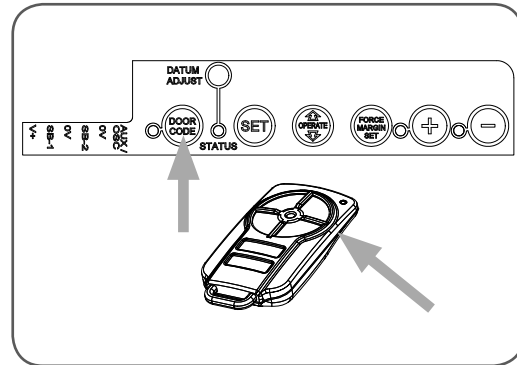

fig 41

Step 18.5 - Coding a Transmitter Button to the Courtesy Light

The transmitter can be programmed to operate the courtesy light on the opener independently of the door moving.

- Briefly press the DOOR CODE button four times, then press it again and hold (will beep five times on fifth press (**Fig. 42**)).
- Press one of the four buttons on the transmitter for two (2) seconds, pause for two (2) seconds, then press the same button again for two (2) seconds.
- Release the DOOR CODE button.
- Press the transmitter button to test the courtesy light.

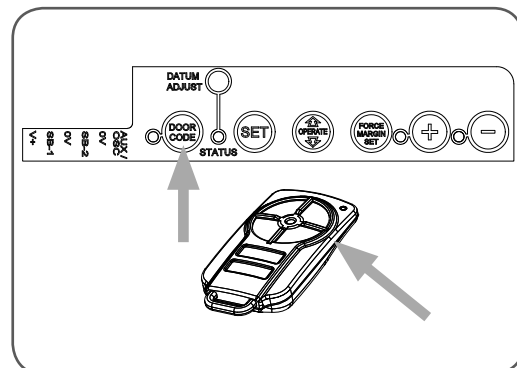

fig 42





Coding Transmitters

fig 43

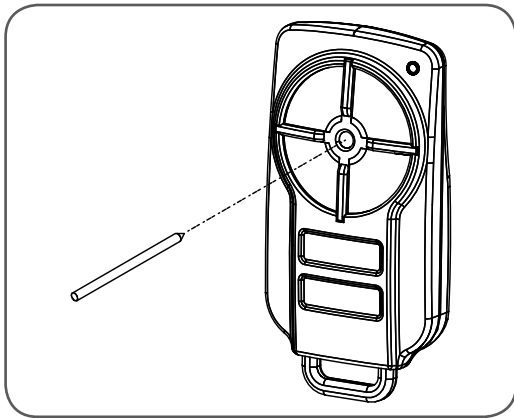

Step 19 - Remotely Coding Transmitters

Using this method transmitters can be coded without access to the opener's control panel as long as a pre-coded transmitter is available.



IMPORTANT NOTE: The door or courtesy light must activate when the steps below are performed. This indicates that the pre-coded transmitter is in range of the opener, and the correct button has been pressed.

- Take any pre-coded transmitter. Press the button for the function to be duplicated and release.
- Using a small needle, press and hold firmly for two seconds through the Coding Hole (**Fig. 43**).
- WITHIN 10 SECONDS take the additional transmitter you wish to code. Decide which button that you want to activate the function to be duplicated (e.g. activate the door, or turn on the courtesy light)
- Hold the new transmitter's button for two seconds, pause for two seconds, hold again for two seconds and then release.
- Wait for 10 seconds and then press the new transmitter's button to test.

fig 44

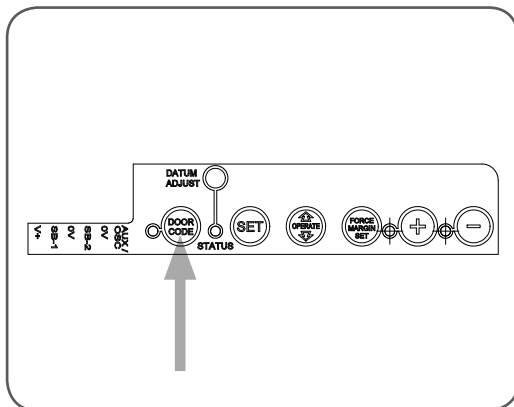

Step 19.1 - Deleting a Stored Transmitter Code

- Select the transmitter you want to delete.
- Press and hold the DOOR CODE BUTTON (**Fig. 44**).
- Press the transmitter button you would like to delete for two seconds, pause for two seconds, press again for two seconds and then release.
- Release the DOOR CODE BUTTON. The code should now be deleted. Confirm this by pressing the transmitter button - the function (e.g. door opening) should not respond.

fig 45

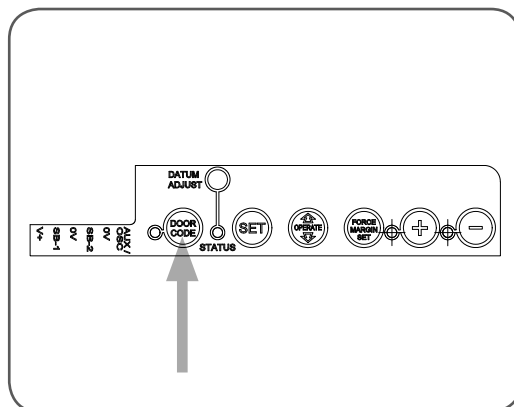

Step 19.2 - Deleting All Transmitter Codes

- Turn off power to the opener.
- While switched off, press and hold the DOOR CODE BUTTON (**Fig. 45**). Turn on power to the opener while holding this button.
- The OPEN LIMIT, CLOSE LIMIT and DOOR STATUS LEDs will illuminate for about five seconds. These LED's will turn off and the CODING LED will illuminate.
- Release the DOOR CODE BUTTON. All stored codes will now be deleted. Confirm this pressing buttons on any previously coded transmitters - the opener should not respond.





Safety Beams Installation

Step 20 - Safety Beams (optional)

Safety Beams extend across the garage door opening. The Safety Beam is designed to detect an obstruction while the door is closing and to send a signal to the garage door opener to reverse or stop the door movement. One or two sets of Safety Beams can be connected to GDO11V2 opener.

Step 20.1 - Fitting the Safety Beam

- Attach the mounting bracket (4) to the adjustment bracket (3) with the pan head screw (6) (supplied). (Fig. 46)
- Attach the bracket (2) to the Safety Beam transmitter with four taptite screws (m3x5) and attach the other side to the adjustment bracket (3) with the pan head screw (6). (Fig. 47)
- Repeat steps a and b to assemble the Safety Beam receiver.

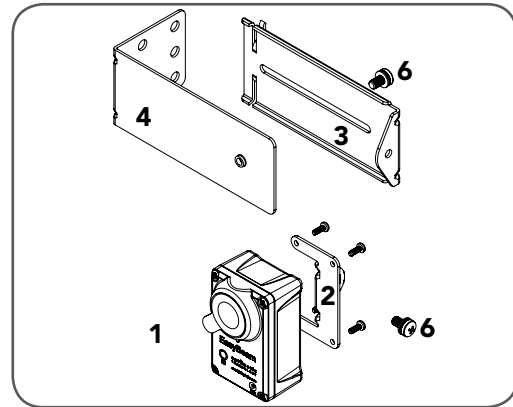

fig 46

Locate the Safety Beam in a strategic location in the doorway. Automatic Technology recommend that the sensor is placed 100mm above the floor level and as close as possible to the door opening. Connect as per the wiring diagram (Fig. 48).

Step 20.2 - Alignment

- Power up the GDO11V2 with the Safety Beam connected. The green LED on the transmitter should turn ON to indicate power is present.
- If the receiver is connected to power and the red LED is flashing while the green LED on the transmitter is on, the transmitter and receiver are not aligned.
- Make horizontal and/or vertical adjustment on the transmitter and/or receiver until the red LED on the receiver turns on, indicating alignment.

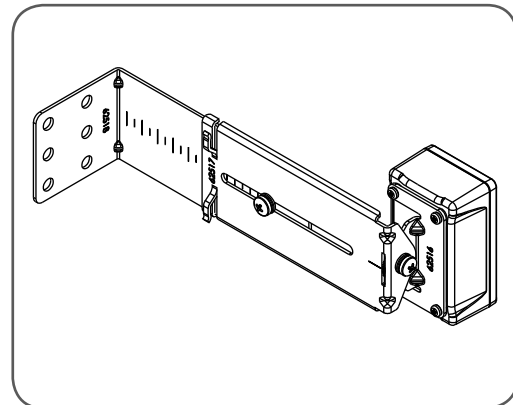

fig 47

NOTE: The sensors need to be 100mm above the floor level however, The exact position must be chosen in such a manner that it suits the application, the environmental conditions and provides maximum safety protection.



WARNING: Install the Safety Beam as per diagram in (Fig. 48). Tampering with the Safety Beam could result in serious personal injury and/or property damage and will void the warranty.



WARNING: Safety Beam must be installed if the closing force as measured at the bottom edge of the door exceeds 400N (40kg).

NOTE: Three wire Safety Beam is not compatible with GDO-11V2 opener.

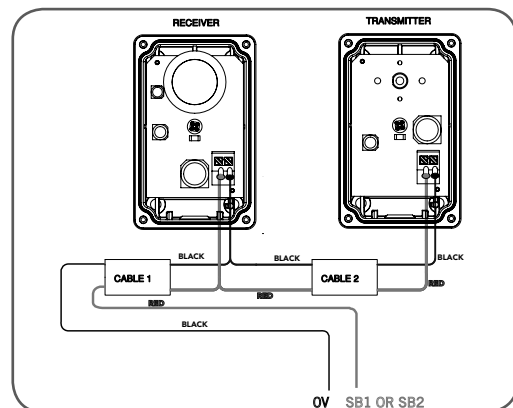

fig 48





Accessories

fig 49

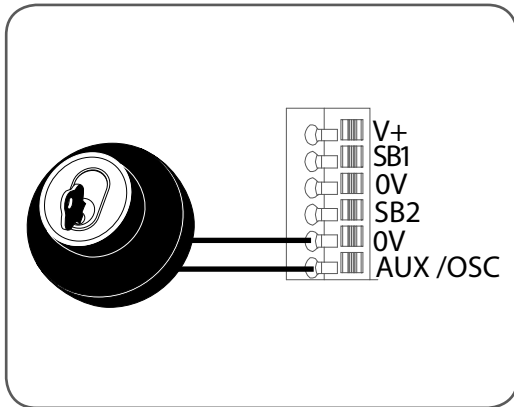

Step 21 - Auxiliary / Key Switch Connection

GDO-11v2 Ero™ has a terminal to either connect key switch to open or close the door or use as an auxiliary output. Connect the key switch as per diagram **Fig. 49**. The auxiliary output can be used to control alarm or another garage door opener with existing garage door remote control. A valid transmission from the pre-coded transmitter will cause the auxiliary output to pulse for approximately 1 (one) second. The maximum DC voltage must not exceed 35 volts DC. Maximum current must not exceed 80 ma. Connect the auxiliary output as per diagram **Fig. 50**.

fig 50

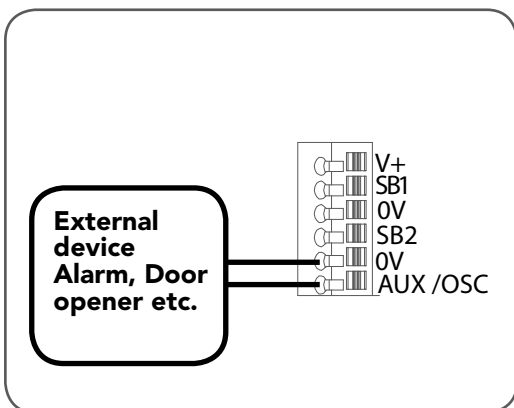

Battery Backup Installation

Step 22.1 - Connect the Battery Backup Kit

- Disconnect power to the opener. Swing open the light diffuser and controls cover. Remove screws marked "S" in **Fig 51** and remove the main cover.
- Mount the PCB support (item no 16) with two screws (item no 12) onto the chassis. Secure the SBC-02 charger board onto PCB support with 3 screws (item no14).
- Remove the shunt plug (if fitted) from j4 connector on the DCB-07 control board and plug the SBC-02 charger harness (item no 9) to j4 connector.
- Feed the SBY-2 battery harness (item no 10) through the grommet on the metal plate and connect to the terminal marked "battery" on the SBC02 as shown in wiring diagram. refit the main cover with screws marked "S" in **Fig 51**.
- Secure the Battery Backup to GDO-11v2 Ero™ with 2 hex standoff M4 (item no 11) and 4 screws (item no 13).

fig 51

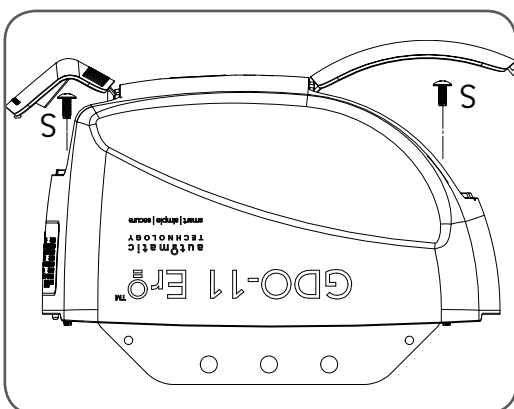

WARNING: After Step 22.1 (f) the opener may become active (even when power is off). This is a result of a residual charge in the batteries.

- Connect battery harnesses item 5 and 10 together (**Fig 49**).
- Reconnect the power.

Step 22.2 - Testing Battery Backup

- Press either the OPERATE button or transmitter to test the opener.
- Whilst door is in motion, disconnect mains power the door should continue to operate as normal.

NOTE: Wait for the door to complete its travel.

- Press the OPERATE button or transmitter to activate the door.
- Whilst door is in motion re-connect power. The door should complete the cycle as normal.

Step 22.3 - Troubleshooting

If door stops or moves very slowly under battery power, the batteries may be weak or have no charge. Connect mains power and allow the batteries to charge. This may take 24 - 48 hours to reach maximum charge capacity.





Accessories

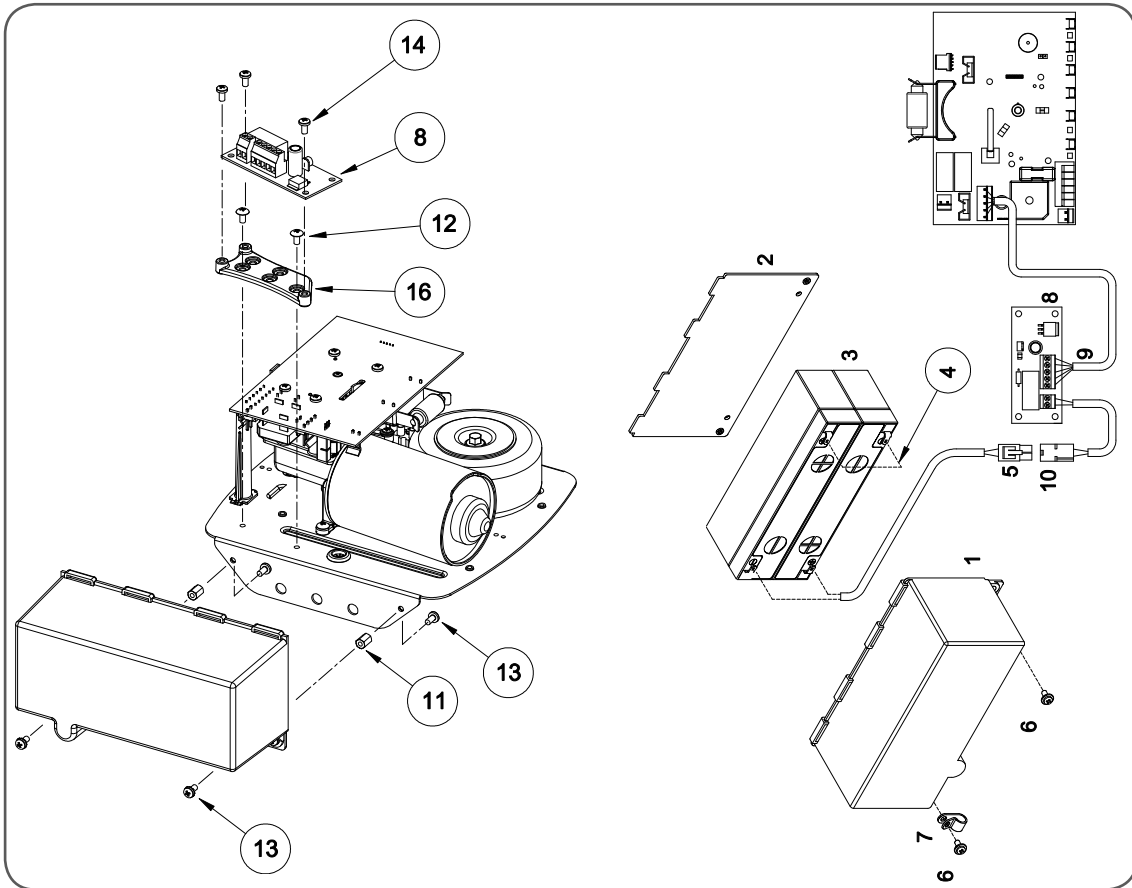

fig 52

BATTERY BACKUP KIT V-06 - ORDER NO. 61932

ITEM	DESCRIPTION	QTY	ORDER CODE
1	BATTERIES COVER	1	16460
2	BATTERIES SUPPORT	1	16480
3	BATTERY 12V SEC12-2.2 AGM TYPE	2	15470
4	BATTERY COUPLING WIRE - ESV24	1	12005
5	BATTERY HARNESS	1	15670
6	PAN HEAD SCREW W/WASHER M4x8	2	10320
7	CABLE CLAMP ACC-1.5 (3/16")	1	11750
8	CHARGER BOARD SBC-02 V-1.01	1	60912
9	SBC-02 CHARGER HARNESS	1	14117
10	SBY-2 BATTERY HARNESS	1	15660

BATTERY PACK # 2

17	TAPTITE SCREW 'P' M4x8	4	10580
18	TAPTITE SCREW 'P' M4x10	2	10570
19	CABLE CLAMP ACC-2.5 (5/16")	1	11760

BATTERY PACK # 3

20	LOCK CIRCUIT BOARD SUPPORT-4	2	11740
21	TAPTITE SCREW 'P' M3.5x8	1	10540
22	CABLE CLAMP ACC-2.5 (3/16")	2	11750
23	PAN HEAD SCREW W/WASHER M4x8	2	10320

BATTERY PACK # 1

11	HEX STANDOFF M4	2	11190
12	THRUSS SERRATION HD SCREW "S" RoHS M4x8	4	10503
13	PAN HEAD SCREW W/WASHER M4x8	4	10320
14	TAPTITE SCREW 'P' M4x8	3	10580
15	BRACKET RA 31x20x31	2	62508
16	PCB SUPPORT 76x27	1	16421
17	CABLE CLAMP ACC-2.5 (5/16")	1	11760





Accessories

Fig 53

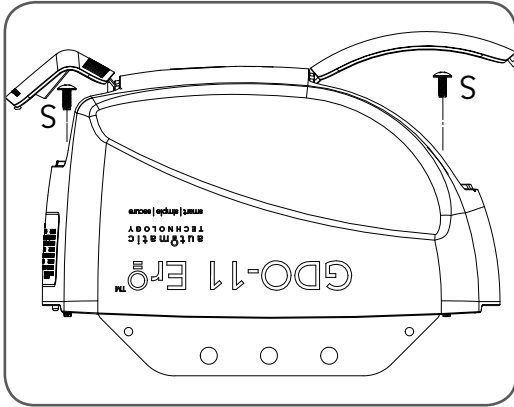

Fig 54

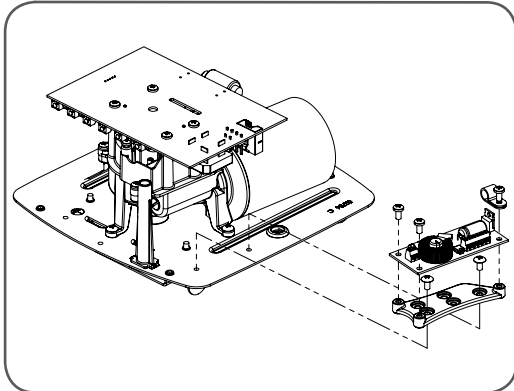

Fig 55

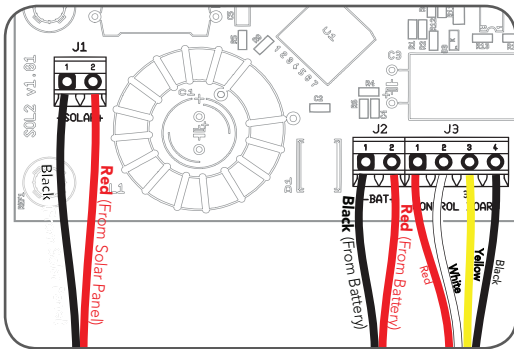
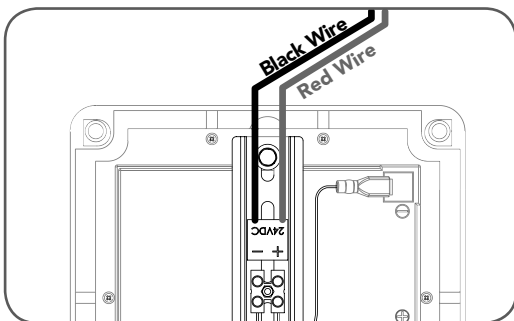

Fig 56



SmartSolar™ Installation



WARNING: Do not connect batteries until Step 23.3

Step 23.1 - Mount the Charger Board

- Disconnect power to the opener.
- Swing open the light diffuser and controls cover. Remove screws marked "S" **Fig 53** and lift up the main cover.
- Remove the transformer and mains power cable.
- Mount the PCB support with two screws. Secure the SOL charger board on to PCB support with 3 screws. (**Fig. 54**).
- Plug the solar charger Board's three wire harness (red/yellow/black) into the control board's "SBY-3" connector on the control board.
- Plug the Charger Board's white one wire harness into the control board's "24vac in" connector.
- Plug the solar shunt (supplied) onto the control board's "JP1" solar connector.



IMPORTANT WARNING: Do not connect battery or solar panel polarity incorrectly - this will result in serious damage to components.

Step 23.2 - Connect the Solar Panel

- Mount the solar panel as outlined in the SmartSolar™ Installation Manual.
- Feed the Solar Panel's cable through black grommet located on the top of the metal plate.
- Connect the **red wire** to the Charger Board's "SOLAR+" connector, and the **black wire** to the "-SOLAR" connector (**Fig. 52**).



WARNING: During Step 24.3 the opener will become active.

Step 23.3 - Mount & Connect the Battery

- Mount the Battery Box close to the opener.
- Feed the 2-core 18awg gauge cable (supplied) through the Battery Box's grommet.
- Connect the **red wire** to the Battery Box's "+" terminal, and the **black wire** to the "-" terminal (**Fig. 56**).
- Feed the other end of the battery cable through the Drive unit's black grommet located on the metal plate.
- Connect the **red wire** to the Charger Board's "BAT+" connector, and the **black wire** to the "-BAT" connector (**Fig. 55**).
- Refit the light diffuser and main cover.

Step 23.4 - Re-setup and Test the Opener

- Setup travel limits and code transmitters as per the GDO-11v2 Ero™ instruction manual.
- Press either the OPERATE button or use a transmitter to operate the opener.





Final Setup

Step 24 - Setting the Pet Mode position

The default Pet Mode height can be changed as follows:

- Drive and stop the door at the desired Pet Mode open position by pressing OPERATE button on the console or the transmitter button coded for O/S/C operation.
- Press and hold the OPEN button (**Fig 57**) for six (6) seconds until the OPEN and CLOSE LED's are lit to record the new pet position.

When activated, Pet Mode drives the door to the preset position from the close position. Pet Mode's active status is indicated by both the OPEN and CLOSE LIMIT LED's being illuminated. If a Pet Mode button is pressed while the door is moving, the door will stop. If a Pet Mode button is pressed when the door is in the Pet position, then the door will close.

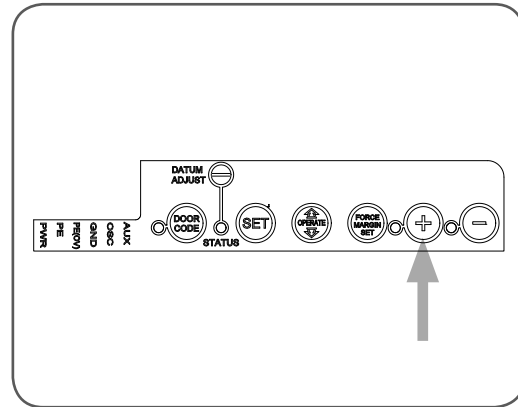

fig 57

Step 25 - Installing the Wall Mounted Transmitter (Optional)

- Remove the faceplate from the transmitter.
- Affix the baseplate in a convenient wall location (**Fig 58**) that is out of reach of children at a height of at least 1.5 metres from the floor and where the door is visible.
- Replace the faceplate.
- To code the transmitter, see Steps 15.2 through 15.3 on page 19.

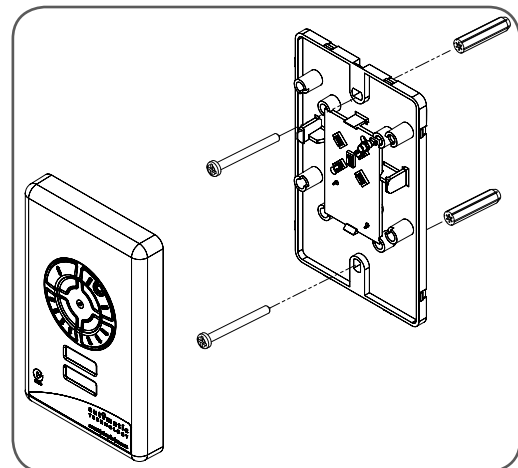

fig 58

Step 26 - Reset all Factory Defaults

- Turn power to opener off.
- Press and hold the SET Button (**Fig 56**).
- Turn power on while holding the SET button. Continue to hold until all the LED's are off.

NOTE: This will not erase transmitter codes stored in the memory.

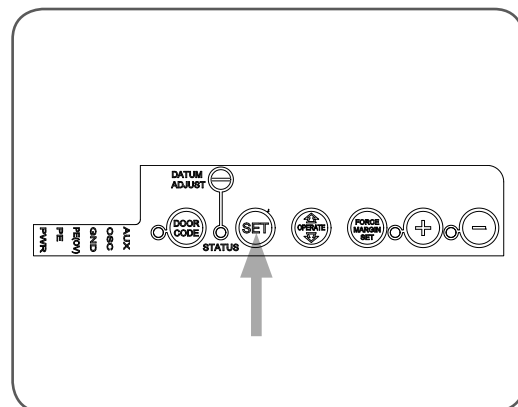

fig 59





Default Settings & Specifications

Factory default settings

	Default	Step	Maximum
Maximum motor run time	60 Secs.	-	-
Courtesy light time	3 Mins. 10 Sec in battery back up mode		
Obstruction force margin	0.5 Amp	0.1	2 Amp

Technical specifications

Power supply	230V - 240V AC 50Hz
Transformer rating	72 VA
Standby power	2.2 Watts
Motor power	90 Watts
Motor type	24V DC permanent magnet
Shuttle travel distance in the C-Rail	2.8m approx (standard)
Maximum shuttle travel distance in the C-Rail	3.5m (with extended C-Rail)
Maximum door opening: (With 3160mm Standard track)	Width: 5500mm (13.5m ²) Height: 2440mm Weight: 100 kg
Minimum Clearance (Bottom of C-Rail to highest point of door travel)	40mm
Short term peak force	650N (65kg)
Lift force	400N (40kg)
Nominal force	150N (15kg)
Receiver type	Multi-frequency FM Receiver
Receiver code storage capacity	8 x 4 button transmitter codes
Transmitter frequency	433.47, 433.92, 434.37 MHz
Coding type	TrioCode™
Number of code combinations	Over 4.29 billion random codes
Code generation	Non-linear encryption algorithm
Transmitter battery	CR 2032
Courtesy light	Festoon style lamp 24 volts 15 watts
Controller fuse	10A slow blow

NOTE: Intermittent operations may occur in areas which experience very strong winds. The strong wind puts extra pressure on the door and tracks which may in turn trigger the safety obstruction detection system intermittently.
Safety Beams should be fitted as added safety in case of entrapment.





Parameters

Door Status Indicators

Door Opener State	OPEN LED (Green)	CLOSE LED (Red)	Beeper
Open	On		
Close		On	
Opening	Flashing		
Closing		Flashing	
Door travel stopped	Flashing	Flashing	
Door obstructed when opening	Flashing		
Door obstructed when closing		Flashing	Beeps as door moves
Opener overloaded	Alternating flashes	Alternating flashes	
Pet Mode Engaged	On	On	
Mains power interrupted	Rapid flashes		

Button Functions

Buttons	Function
OPERATE	Opens/Stops/Closes the door
DOOR CODE	Codes a transmitter button for operate function, Vacation function, Auxiliary function, Pet mode and Light function
FORCE MARGIN SET & OPEN	Increases the obstruction force margin setting
FORCE MARGIN SET & CLOSE	Decreases the obstruction force margin setting
FORCE MARGIN SET (then) SET	Resets the factory default force margin settings
CLOSE (for 6 secs.)	Clears the door limits set positions. Limits then need to be reset
PLUS(+) (for 6 secs.)	Enters pet (pedestrian) position mode
SET (then power on) & hold until all LED's are off	Deletes control parameters excluding transmitter storage memory
DOOR CODE (then power on) & hold until all LED's are off	Deletes all transmitter storage memory
SET & DOOR CODE (the power on) and hold until all LED's are off	Deletes all control parameters and transmitter storage memory.
SET	Re-initialises the Opener to re-calculate force margin





Troubleshooting Guide

Symptom	Possible cause	Remedy
Door will not operate	Mains power not switched on	Switch on mains power
	Door is obstructed	Remove obstruction
	Door is locked or motor jammed	Unlock door or remove jam
	Door tracks/hardware damaged	Door requires service/repair by qualified technician
Door starts to close but automatically reverses to open position	Adverse weather conditions (wind or cold) causing door to stiffen and become tight in the tracks	Increase force margin setting. See Step 17 on page 21
	Possible obstruction in the doorway	Remove obstruction
Door operates from drive unit (operate) button but not from transmitter. *See note	Transmitter code not stored in memory	Code transmitter into opener's memory. Refer Step 18.1 on page 22
	Flat battery	Replace battery
Door will not close fully	Door limits position need to be reset	Reset limits positions. Refer Step 15.4 on page 19
Door will not open fully	Door limits position need to be reset	Reset limits positions. Refer Step 15.4 on page 19
Courtesy light not working	Faulty light	Replace lamp
Door does not reverse open when Safety Beam is obstructed during close cycle	Safety Beam not aligned correctly	Re-align the Safety Beam
	Safety Beam is obstructed	Remove obstruction

PLEASE NOTE:

Some areas may be prone to excessive radio interference brought on by devices such as cordless telephones, wireless stereo headphones and baby monitors. It is possible that these devices could cause a degree of interference such as to greatly reduce the range of the transmitter. In such an instance please contact your Automatic Technology dealer for an alternative frequency replacement kit. As this is not a warrantable situation but an environmental issue. Charges may apply for the changeover.





Maintenance

Maintenance

Whilst your opener does not require any periodic maintenance, the door that it is fitted to, does. Your garage door is a large, heavy, moving object and should be tested regularly to ensure it is in good condition. A poorly maintained door could cause fatal or serious injuries or serious damage to property.

To ensure a long and trouble free life for your opener, the following is recommended:

Monthly

- Disengage the opener and manually operate the door: The door must be smooth to operate by hand. An operating force on the bottom of C-Rail should not exceed 150N (15kg) force.
- Each month, check that the opener reverses when the door contacts a 40mm high object placed on the floor (AS3350).

NOTE: If the door does not operate smoothly, call your door professional.

Yearly

Automatic Technology suggests you contact your door professional to perform an annual door service.



CAUTION: Frequently examine door, particularly cables, springs and mountings for signs of wear, damage or imbalance. Do not use if repair or adjustment is needed since a fault in the installation or an incorrectly balanced door may cause injury. (AS3350)



Adjustments should only be carried out by experienced persons, as this function can be dangerous if not performed under strict safety procedures.



WARNING! Failure to maintain your garage door may void the warranty on your garage door opener.

Service Record

Record any maintenance in the following table to assist in any warranty service.

Date	Service by	Signature	Invoice No.	Amount





Parts Listing

fig 60

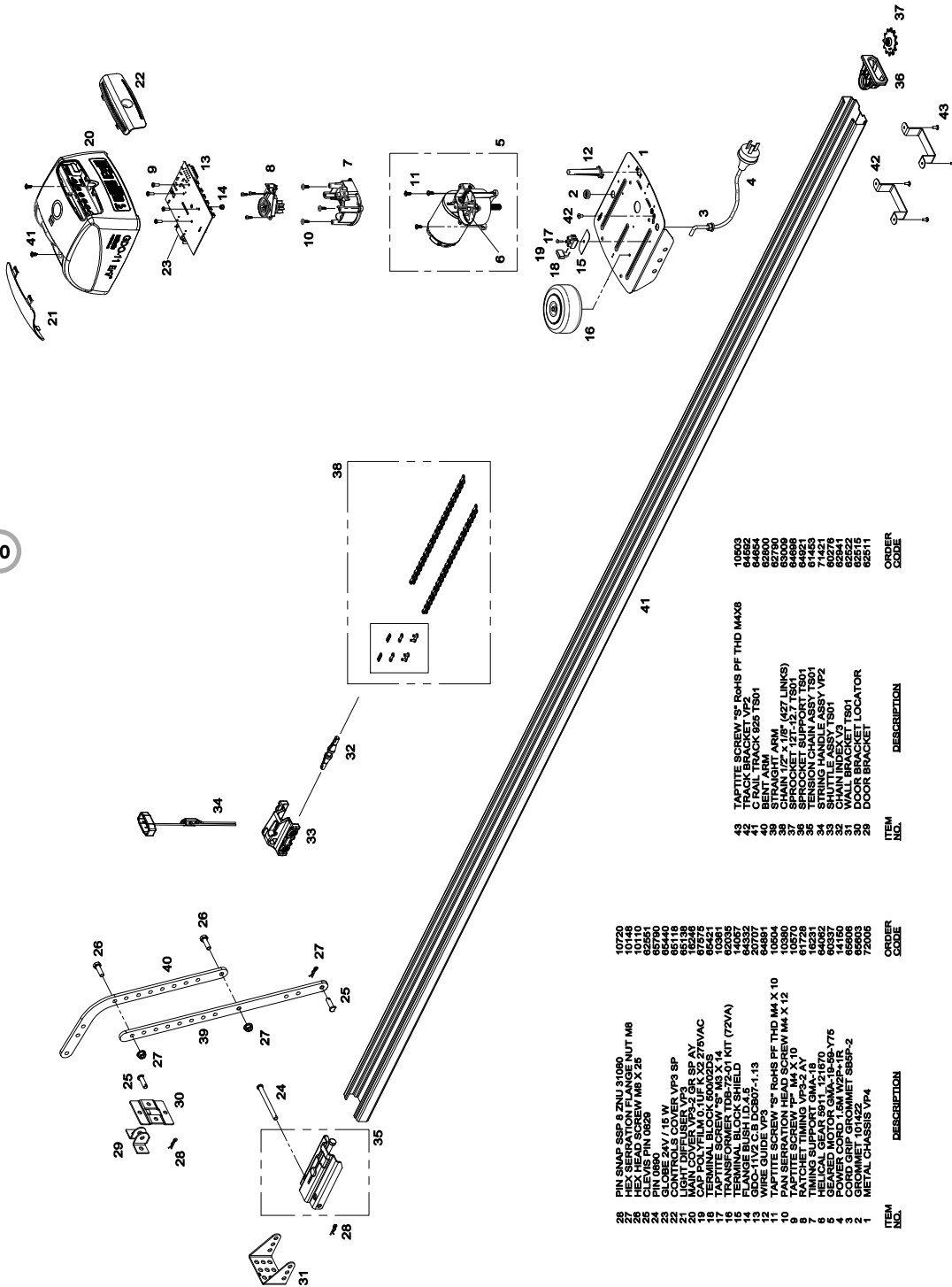

ITEM NO.	DESCRIPTION	ORDER CODE
27	PIN SNAP 8 ZN J 31090	10720
28	HEX SERRATION FLANGE NUT M8	10148
29	HEX HEAD SCREW M8 X 25	07010
24	PIN 0890	65790
22	CONROLS COVER VP3 SP	65116
21	LIGHT DIFFUSER VP3 SP AY	65138
19	CAP POLYFILM 0,1 UFK 32 278VAC	65776
18	TERMINAL BLOCK 60002DS	65421
16	TRANSFORMER TSB-72-01 KIT (72VA)	62035
15	TERMINAL BLOCK SHIELD	44057
14	GEAR 11V2 C B DCR07-1-13	20707
12	WIRE GUIDE V3	64651
10	PAN SERRATION HEAD SCREW M4 X 10	10390
8	TAPTITE SCREW TP M4 X 10	10570
7	TENSION CHAIN ASSY TS01	61453
6	HELICAL GEAR 8911 121670	64092
4	POWER CORD 1,5M W2P+1R	14150
3	CORD GRIP GROMMET 88BP-2	65806
1	METAL CHASSIS VP4	72006

ITEM NO.	DESCRIPTION	ORDER CODE
43	TAPTITE SCREW TP RchS PF THD MAX8	10503
41	C TRAIL TRACK 524 TS01	64654
40	BENT ARM	62900
39	CHAIN 1/2" X 1/8" (427 LINKS)	63069
38	SPROCKET 127-12,7 TS01	64889
36	TENSION CHAIN ASSY TS01	61453
35	STRING HANDLE ASSY VP2	71421
34	CHAIN INDEX V3	62841
32	CHAIN INDEX V3	62552
31	DOOR BRACKET LOCATOR	62511
29	DOOR BRACKET	62511





Warranty and Exclusion of Liability

1. This Warranty is given by Automatic Technology (Australia) Pty Ltd (ABN 11 007 125 368) (ATA), 6-8 Fiveways Boulevard, Keysborough 3173, 1300 133 944, sales@ata-aust.com.au
 2. The Competition and Consumer Act 2010 (including the Australian Consumer Law) and other relevant statutes provide a set of statutory consumer guarantees and other legal rights that cannot be excluded, restricted or modified by contract. This Warranty is in addition to and does not affect any of your rights under the Australian Consumer Law and other relevant statutes.
 3. Our goods come with guarantees that cannot be excluded under the Australian Consumer Law. You are entitled to a replacement or refund for a major failure and for compensation of any other reasonably foreseeable loss or damage. You are also entitled to have the goods repaired or replaced if the goods fail to be of acceptable quality and the failure does not amount to a major failure.
 4. Subject to your non-excludable rights under the Australian Consumer Law, ATA expressly excludes any liability for consequential loss, incidental or indirect damages (including but not limited to damages for loss of business profits, business interruption and loss of business information) due to a defect of the GDO-11 Ero™ (Product). In particular any loss or damage caused to other equipment or accessories used with the product or any loss resulting from a delay in repair is excluded to extent permitted by law.
 5. Subject to all of the matters set out below, ATA warrants in relation to the Product that:
 - (a) the Product's overhead door opener drive units will be free of any defects in material and workmanship for at least 24 months after the date of purchase (as evidenced by the sales docket receipt), or 5,000 cycles, which ever occurs first; and
 - (b) the Product's other components and accessories will be free of any defects in material and workmanship for at least 12 months after the date of purchase (as evidenced by the sales docket receipt).
 6. No additional warranty will apply for Products repaired during the relevant warranty period.
 7. For all Products repaired outside the warranty period, a six (6) month warranty that the Product will be free of any defects in material and workmanship will apply from the date of dispatch of the Product to you. ATA may charge you for any repairs undertaken outside the warranty period, and will provide you with a quotation in relation to any such costs for your approval before proceeding with any repairs.
 8. This Warranty applies only where you:
 - (a) immediately notify ATA at the contact details provided in paragraph 1 above or notify the or the retailer that you purchased the Product from of the alleged defect;
 - (b) return the product to the retailer that you purchased the Product from; and
 - (c) present the relevant sales docket and this Warranty document to the retailer to confirm the date of purchase.
 9. Except for this Warranty, ATA gives no warranties of any kind whatsoever (whether express or implied), in relation to the product, and, subject to paragraph 1 above, all warranties of whatsoever kind relating to the product are hereby excluded.
 10. This Warranty excludes damage resulting from:
 - (a) normal wear and tear;
 - (b) accidental damage;
 - (c) incorrect installation of the Product;
 - (d) blown fuses, electrical surges, power surges or power spikes;
 - (e) theft, fire, flood, rain, water, lightning, storms or any other acts of God;
 - (f) any installation, configuration or use of the Product contrary to the instructions supplied with the Product;
 - (g) maximum continuous operating time exceeding 1 minute in 10;
 - (h) the operating force exceeding 15kg* (150 Newton) when moving the door manually to the open or closed position;
 - (i) the door surface area exceeding 13.5m²;
 - (j) the door used with the Product not being in safe working order and condition;
 - (k) repairs which are not authorised by ATA;
 - (l) any failure to install or maintain the Product in accordance with the instructions supplied with the Product;
 - (m) any use which is not in accordance with the instructions provided with the Product;
 - (n) deliberate or negligent damage to the Product;
 - (o) any unauthorised modification to the Product;
 - (p) faulty or unsuitable wiring in the building in which the Product is installed;
 - (q) damage caused by insects;
 - (r) any cost or expense relating to the recall of the Product;
 - (s) installation of a residential garage door opener in a commercial or industrial premises or in a dwelling other than a single-family dwelling;
 - (t) radio or electrical interference; or
 - (u) acts or omissions of any person (including service providers approved by ATA) other than ATA.
 11. ATA's liability under this Warranty is limited, at ATA's absolute option, to replacing or repairing the product which ATA, in its unfettered opinion, considers to be defective either in material and/or workmanship or to credit the dealer with the price at which the product was purchased by the dealer.
 12. This Warranty does not extend to cover labour for installation of the Product following repairs, the cost of which must be borne by you.
 13. This Warranty is limited to Return-to-Base (RTB) repair and does not cover labour for on-site attendance, the cost of which must be borne by you.
 14. Except as specified in this Warranty, ATA will not charge you for any repairs or replacements conducted under the Warranty. However, ATA will charge you for any repairs which are not within the scope of this Warranty (or which are not required to be undertaken free of charge pursuant to the Australian Consumer Law).
 15. This Warranty is void if the Product is not returned to the manufacturer in original or suitably secure packaging.
 16. This Warranty is only applicable for repairs to the product carried out within Australia.
 17. This Warranty does not cover consumable items including, without limitation, globes, batteries and fuses.
 18. This Warranty is not transferable.
 19. Where the Product is retailed by any person other than ATA, except for the warranty set out above, such person has no authority from ATA to give any warranty or guarantee on ATA's behalf in addition to the warranty set out above.
 20. Any provision of this Warranty that is prohibited or unenforceable in any jurisdiction is ineffective as to that jurisdiction to the extent of the prohibition or unenforceability. That does not invalidate the remaining provisions of this Warranty nor affect the validity or enforceability of that provision in any other jurisdiction.
 21. Products presented for repair may be replaced by refurbished goods of the same type rather than being repaired. Refurbished parts may be used to repair the Product.
- NOTES:
1. One (1) cycle = one (1) open and one (1) close action of the door.
 2. This Warranty is to be read in conjunction with the owner's copy of the installation instruction manual.
 3. * The door that the Product is used with should be balanced in such a way that the user is able to open or close the door manually using a force not greater than 150 Newton (15 kg), other than to initially cause the door to start moving, which may require force in excess of that specified in this paragraph.





© February 2012 Automatic Technology (Australia) Pty Ltd. All rights reserved. TrioCode™ and Ero™ are trademarks of Automatic Technology (Australia) Pty Ltd. No part of this document may be reproduced without prior permission. In an ongoing commitment to product quality we reserve the right to change specification without notice. E&OE.

automatic
TECHNOLOGY

smart | simple | secure

an alesco company

Automatic Technology (Australia) Pty Ltd

ABN 11 007 125 368

6-8 Fiveways Boulevard
Keysborough, Victoria, 3173, Australia

P 1300 133 944

+61 2 9722 5666 (International Enquiries Only)

E sales@ata-aust.com.au

www.ata-aust.com.au