

Symptom	Possible cause	Remedy
The opener does not work from the transmitter	Garage door in poor condition e.g. springs may be broken	Check the door's operation
One transmitter works but the others do not	Faulty transmitter	Replace transmitter
The chain moves but the door remains stationary	The opener is disengaged	Re-engage the opener
Motor is running but chain is not moving	Damage motor assembly	Contact your dealer for support.
The door reverses for no apparent reason	This may occur occasionally from environmental conditions such as areas that are windy, dusty or have extreme temperature changes.	Ensure the door runs smoothly before increasing the force pressure.
Auto Close not working	Safety Beam or wiring faulty	Repair Safety Beam or replace wiring.
The door stops or moves (Optional Battery Back Up Accessory)	The door stops or moves very slowly under battery power	Connect mains power and leave the batteries to charge. The batteries may have little or no charge.
The SERVICE LED has started to flash and is beeping numerous times	A fault has been detected. The fault will be active each time an attempt is made to operate the door.	Record opener function (How many beeps?) then press the SET button once to reset the opener. If the fault continues to be tripped contact 13 62 63 for support.
The Open (Green) LED and Close (Red) LED are flashing alternately	Opener is overloaded	Check the doors operation by disengaging the motor and ensuring the door runs smoothly. If necessary make door adjustments or contact your door professional.
The Open (Green) LED continues to flash	Door obstructed when opening	Clear away any obstructions and test door opens correctly. (If door is damaged, contact your door professional).
The Close (Red) LED continues to flash	Door obstructed when closing	Clear away any obstructions and test door closes correctly. (If door is damaged, contact your door professional).
Limits may be cleared		Remove all power sources (including the battery backup). Wait till all lights are out (10-15 secs), then reconnect power. If Red LED is flashing, limits are not set. Reset Limits.

Troubleshooting Guide

Important Safety Instructions

This automatic garage door opener is designed and tested to offer safe service provided it is installed and operated in strict accordance with the following safety rules. Failure to comply with the following instructions may result in death, serious personal injury or property damage.

- WARNING!**
- The door may operate unexpectedly, therefore do not allow anything to stay in the path of the door.
 - When operating the manual release while the door is open, the door may fall rapidly due to weak or broken springs, or due to being improperly balanced.
 - The drive must not be used with a door incorporating a wicket door, unless the drive cannot be operated with the wicket door open.
 - The drive is intended to be installed at least 2.5m above the floor.
 - Do not disengage the opener to manual operation with children/persons or any objects including motor vehicles within the doorway.
 - If the door is closing and is unable to re-open when obstructed, discontinue use. Do not use a door with faulty obstruction sensing
 - When using auto close mode, a **Photo Electric beam** must be fitted correctly and tested for operation at regular intervals. **Extreme caution** is recommended when using auto close mode. **All safety rules** must be followed.
 - Place opener in protected area so that it does not get wet.
 - Do not spray with water.
 - Disconnect the power cord** from mains power before making any repairs or removing covers. Only **experienced** service personnel should remove covers from the opener.
 - If the power supply cord is damaged, it **must** be replaced by an Automatic Technology service agent or suitably qualified person.
 - Connect the opener to a properly **earthed** general purpose 240V mains power outlet installed by a qualified electrical contractor.
- ELECTROCUTION!**
- CAUTION:** Emergency Access
- If garage has no pedestrian entrance door, an emergency access device should be installed. This accessory allows manual operation of the garage door from outside in case of power failure.
 - Practice correct lifting techniques (carton weighs approx 9kgs)
 - Practice correct lifting techniques when required to lift the door as per installation instructions.
 - Ensure ladder is the correct type for job.
 - Ensure ladder is on flat firm ground that will take the weight without the legs sinking.
 - Ensure user has 3 points of contact while on ladder.
 - Place a 2 metre exclusion zone around area under the door while it is unsecured.
 - Do not move under a door while it is on the door support (or ladder)
 - Follow the installation instructions
 - Fit door support (or ladder) snugly under door before removing bracket.
 - Ensure door support (or ladder) is on flat ground
 - Examine the door installation, in particular cables, springs and mountings for signs of wear, damage and imbalance.
 - The garage door must be **well balanced**. Sticking or binding doors must be repaired by a qualified garage door installer prior to installation of the opener.
 - Remove or disengage** all garage door locks and mechanisms prior to installation of the opener.
 - Never plug in and operate opener prior to installation.
 - Keep hands and loose clothing clear of door and guides at all times.
 - DO NOT** operate the opener unless the garage door is in full view and free from objects such as cars and children/people. Make sure that the door has finished moving before entering or leaving the garage
 - In order for the opener to **sense** an object obstructing the door way, some **force** must be exerted on the object. As a result the object, door and/or person may suffer minor **damage** or **injury**.
 - Ensure the garage door is in good working order by undertaking regular servicing.
 - Install the optional wall transmitter in a location where the garage door is visible, but out of the reach of children at a height of at least 1.5m.
 - Photo Electric beams must be installed if the closing force at the bottom edge of the door exceeds 400N (40kg)
- Muscular strain
- Fall from ladder
- Crush injury from unsecured door
- Garage Door
- Entanglement
- Entrapment under operating door

Safety Obstruction Forces

Controll-A-Door[®] Advance & Controll-A-Door[®] Prodigy

Sectional Door Opener SDO-2 Tri-Tran+™ Installation Instructions

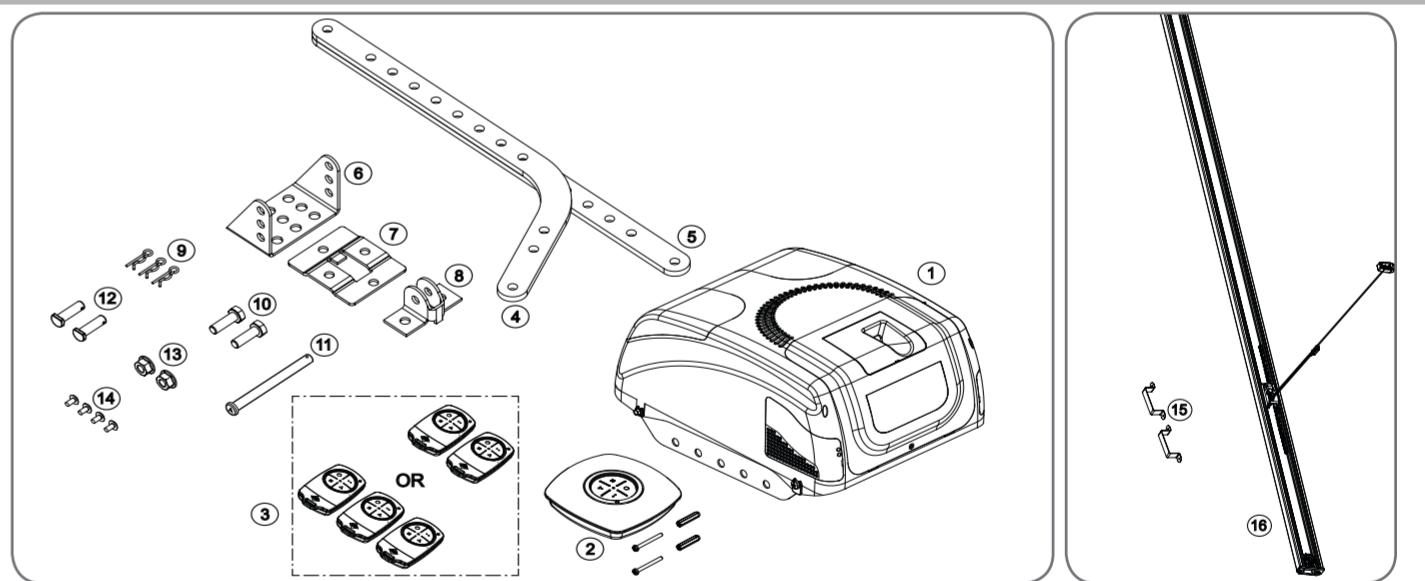

Kit Contents

- 1 x SDO-2 drive unit
- 1 x Wall mount transmitter with battery and screws
- Advance: 3 x Transmitters and batteries
OR
Prodigy: 2 x Transmitters and batteries
- 1 x Bent arm door attachment
- 1 x Straight arm door attachment
- 1 x Wall bracket TS01
- 1 x Door bracket Locator
- 1 x Door bracket
- 3 x Pin Snap SSP 8 ZNU 31080
- 2 x Hex Head screw M8x25
- 1 x Pin 0890
- 2 x Clevis Pin 0829
- 2 x Hex Serration flange nut M8
- 4 x Hex flange screw tapitite 'S' M4 x 10 PLUS
- 2 x Track Bracket
- 1 x Pre-Assembled Single Piece C-Rail

Tools Required

- Ladder
- Adjustable Wrench
- Socket set
- Drill
- Screwdrivers
- Marker Pen
- Door Stand

Important Note:

Only Tri-Tran+™ Technology Transmitters and Keypads are compatible with these SDO-2 products.

Power Supply

Properly earthed 3 pin single -phase power is required. **WARNING!** A portable power generator is not recommended due to spikes, surges and fluctuations in the supply.

Head Room

The minimum height required between the highest point of the door's travel and the ceiling is 57mm.

Quick Install Guide

C-Rail Attachment Single piece

C-Rails are pre-tensioned during manufacturing for transport. Some extra tension may be required after installation.

If the C-Rail needs to be shortened or lengthened (using the extension kit) ensure these modifications are made to the drive unit end.

To prevent scratching the unit after attaching the C-Rail, place the drive unit back in its packing box.

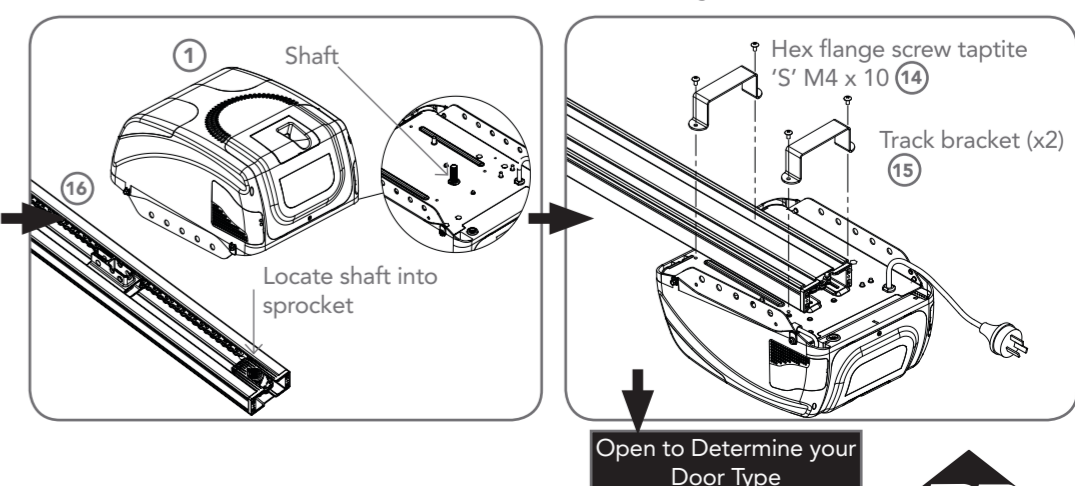

Open to Determine your Door Type

- To Recall Factory Set Force**
- Hold down the FORCE MARGIN SET button and the LIMIT SET button for two seconds.
 - Release both buttons. The default setting should now be recalled.
- To Recalculate Force Margins**
- Press and hold the FORCE MARGIN SET button for six (6) seconds, the SET Button for six (6) seconds, the OPERATE button.
 - While holding the FORCE MARGIN SET button, press the MINUS (-) button. Each time the MINUS (-) button is pressed to indicate a decrease in force.
 - If the CLOSE LIMIT LED flashes continuously when the MINUS (-) button is being pressed, this indicates that the maximum force setting has been reached.
 - Test the force again as per Testing Close Cycle and Testing Open Cycle.
- To Decrease Force Pressure**
- Hold down the FORCE MARGIN SET button.
 - While holding the FORCE MARGIN SET button, press the MINUS (-) button. Each time the MINUS (-) button is pressed to indicate a decrease in force.
 - If the CLOSE LIMIT LED flashes continuously when the MINUS (-) button is being pressed, this indicates that the maximum force setting has been reached.
 - Test the force again as per Testing Close Cycle and Testing Open Cycle.
- To Increase Force Pressure**
- Hold down the FORCE MARGIN SET button.
 - While holding the FORCE MARGIN SET button, press the PLUS (+) button. Each time the PLUS (+) button is pressed to indicate an increase in force.
 - If the OPEN LIMIT LED flashes continuously when the PLUS (+) button is being pressed, this indicates that the maximum force setting has been reached.
 - Test the force again as per Testing Close Cycle and Testing Open Cycle.

Adjusting Safety Obstruction Force

The Safety Obstruction Force is calculated automatically during setup. Adjusting this is normally only necessitated by environmental conditions such as windy or dusty areas, and areas with extreme temperature changes.

NOTE: Once the travel limits are set and safety obstruction force tested check the chain or belt tension. As per the sticker on the C-rail the chain or belt should sag slightly, so there is a 5mm gap between the bottom of the C-rail and the chain or belt.

The tension can be varied by using a spanner to adjust the bolt at the door end of the C-rail.

Be sure not to over-tension the chain or belt as this can cause damage to the C-rail or opener.

- WARNING!** Take care when testing or adjusting the Safety Obstruction Force. Excessive force may cause SERIOUS PERSONAL INJURY and/or PROPERTY DAMAGE.
- WARNING!** If the door falls these tests, put the opener into manual mode, only operate the door by hand and call for service.
- WARNING!** Photo electric beams must be installed if the closing force at the bottom edge of the door exceeds 400N (40kg) force.
- Testing Close Cycle**
- Press the programmed transmitter to open the door.
 - Place a piece of timber approximately 40mm high on the floor directly under the door.
 - Press the programmed transmitter to close door.
 - The door should strike the object and re-open.
- Testing Open Cycle**
- Press the transmitter to close the door.
 - Press again to open the door.
 - When the door reaches approximately half way, firmly grab the door's bottom rail - the door should stop.
 - If the door does not reverse readily when closing, or stop when opening, the force may be excessive and need adjusting.

Determine the Door Type

Sectional door with track / B&D Flex-A-Door®

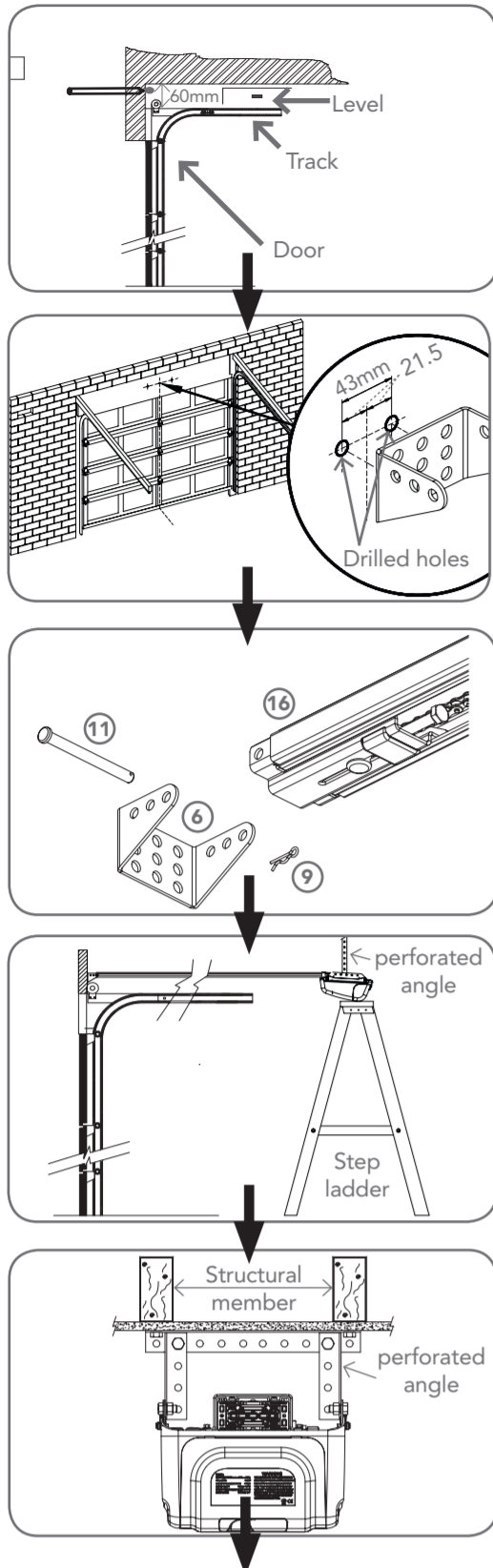

- Open the door and find the highest point of travel of the top door panel.
- Using a level, transfer this height to the wall above the door and mark a line 60mm above it.
- WARNING! Make sure concrete, brick wall or timber lintels are solid and sound so as to form a secure mounting platform.**
- Determine the centre point on the wall above and on top of the door. Draw two lines extending 21.5mm (43mm in total) from each side of the centre point.
- Centre the bracket over the intersection of these two lines. Mark centres for holes. Drill holes into wall and secure as follows: **IF CONCRETE OR BRICK** 8mm drill bit for holes 8mm (5/8") loxins / dynabolts to secure **IF TIMBER** min. 50mm wood screw or similar to secure
- Leave the drive unit in its packing box on the floor for protection and lift the other end of the C-Rail.
- Attach the C-Rail assembly ⑫ to the wall bracket ⑥ with the 90mm long clevis pin ⑪ and secure with the supplied snap pin ⑨.
- Raise the drive unit from the packing box and support it in the horizontal position with a step ladder.
- Line up the track perpendicular to the wall.
- Secure the perforated angle (not supplied) to the ceiling above where drive unit's mounting holes will be once fully installed.
- Connect the drive unit to the ceiling mounted perforated angle with M8x20mm screws and nuts (not supplied). Strips should not extend more than 18mm below centre of drive unit mounting holes.
- To prevent moisture on the C-rail running into the powerhead it is recommended a strip of silicon sealant is placed across the top of the C-rail just before the opener.

One piece door with track (T-Type)

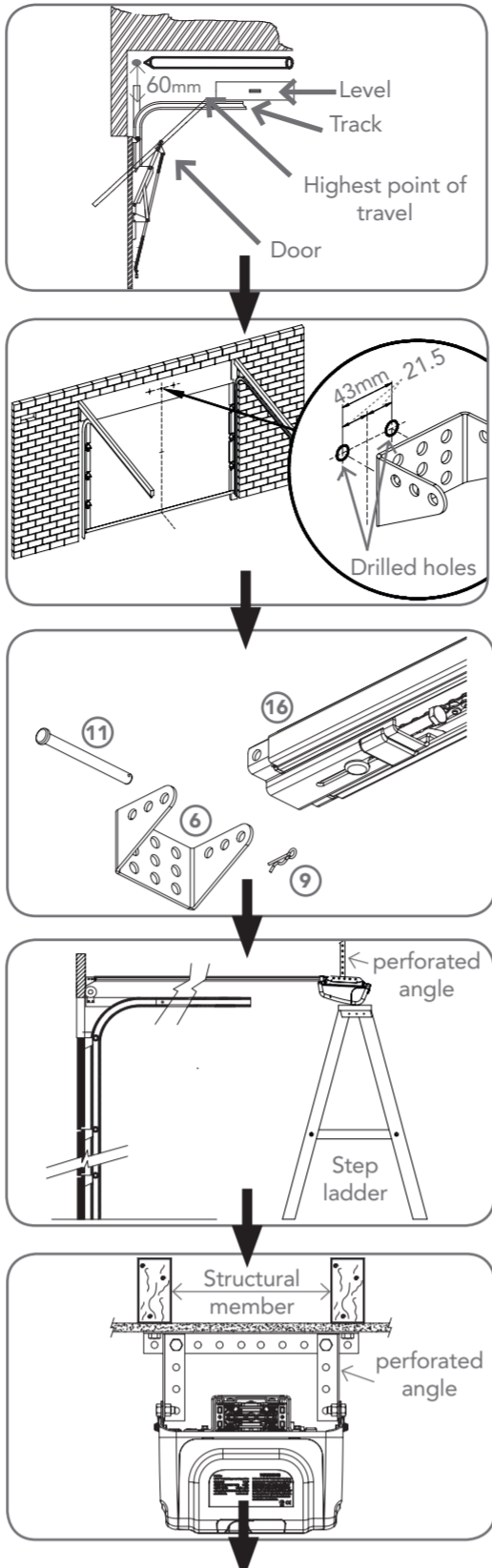

- Open the door and find the highest point of travel of the top door panel.
- Using a level, transfer this height to the wall above the door and mark a line 60mm above it.
- WARNING! Make sure concrete, brick wall or timber lintels are solid and sound so as to form a secure mounting platform.**
- Determine the centre point on the wall above and on top of the door. Draw two lines extending 21.5mm (43mm in total) from each side of the centre point.
- Centre the bracket over the intersection of these two lines. Mark centres for holes. Drill holes into wall and secure as follows: **IF CONCRETE OR BRICK** 8mm drill bit for holes 8mm (5/8") loxins / dynabolts to secure **IF TIMBER** min. 50mm wood screw or similar to secure
- Leave the drive unit in its packing box on the floor for protection and lift the other end of the C-Rail.
- Attach the C-Rail assembly ⑫ to the wall bracket ⑥ with the 90mm long clevis pin ⑪ and secure with the supplied snap pin ⑨.
- Raise the drive unit from the packing box and support it in the horizontal position with a step ladder.
- Line up the track perpendicular to the wall.
- Secure the perforated angle (not supplied) to the ceiling above where drive unit's mounting holes will be once fully installed.
- Connect the drive unit to the ceiling mounted perforated angle with M8x20mm screws and nuts (not supplied). Strips should not extend more than 18mm below centre of drive unit mounting holes.
- To prevent moisture on the C-rail running into the powerhead it is recommended a strip of silicon sealant is placed across the top of the C-rail just before the opener.

One piece door without track (Tilt Door / J-Type)

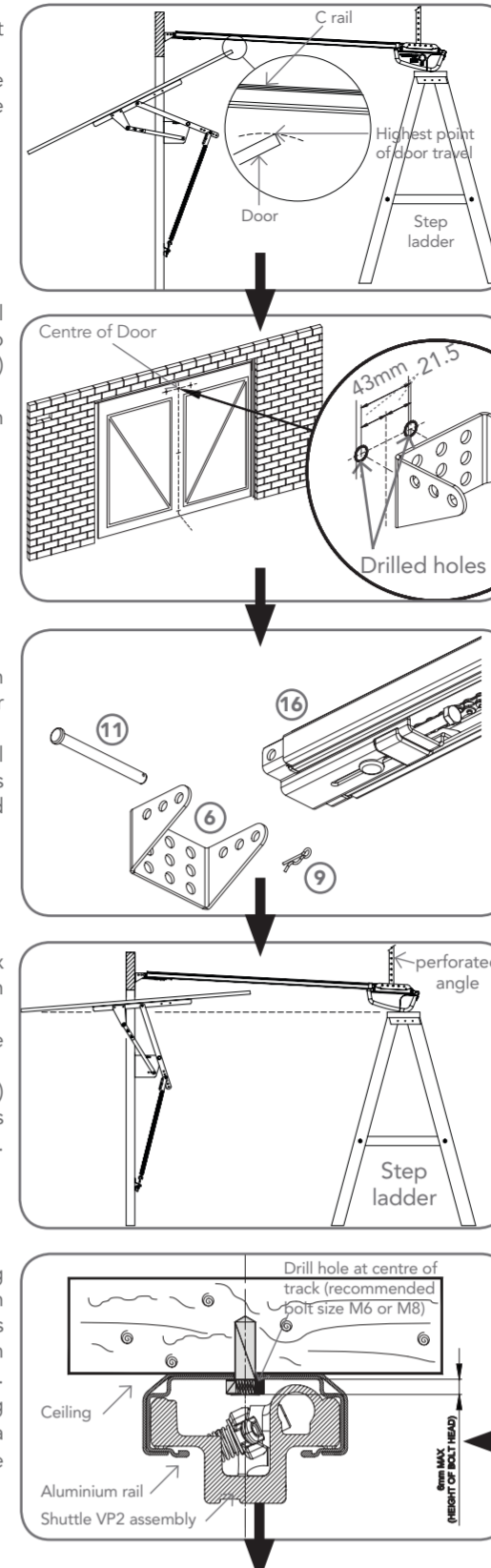

- Open the door and find the highest point of travel of the top edge of the door.
- Using a level, transfer this height to the wall above the door and mark a line 25mm above it.
- WARNING! Make sure concrete, brick wall or timber lintels are solid and sound so as to form a secure mounting platform.**
- Determine the centre of the door. Mark this location both on the line drawn in step (b) and on top of the door. Draw two lines extending 21.5mm (43mm in total) from each side of the centre point on the wall.
- Centre the bracket over the intersection of these two lines. Mark centres for a minimum of two holes.
- Drill holes into wall and secure as follows: **IF CONCRETE OR BRICK** 8mm drill bit for holes 8mm (5/8") loxins / dynabolts to secure **IF TIMBER** min. 50mm wood screw or similar to secure.
- Leave the drive unit in its packing box on the floor for protection and lift the other end of the C-Rail.
- Attach the C-Rail assembly ⑫ to the wall bracket ⑥ with the 90mm long clevis pin ⑪ and secure with the supplied snap pin ⑨.
- Raise the drive unit from the packing box and support it in the horizontal position with a step ladder.
- Line up the track perpendicular to the wall.
- Secure the perforated angle (not supplied) to the ceiling above where drive unit's mounting holes will be once fully installed.
- Connect the drive unit to the ceiling mounted perforated angle with M8x20mm screws and nuts (not supplied). Strips should not extend more than 18mm below centre of drive unit mounting holes.
- To prevent moisture on the C-rail running into the powerhead it is recommended a strip of silicon sealant is placed across the top of the C-rail just before the opener.

Alternative Mounting Option
The opener can be fastened to the roof by driving a bolt through the C-Rail into a structural timber support. The bolt head's height must not exceed 6mm.

Mounting Door Bracket & Arms

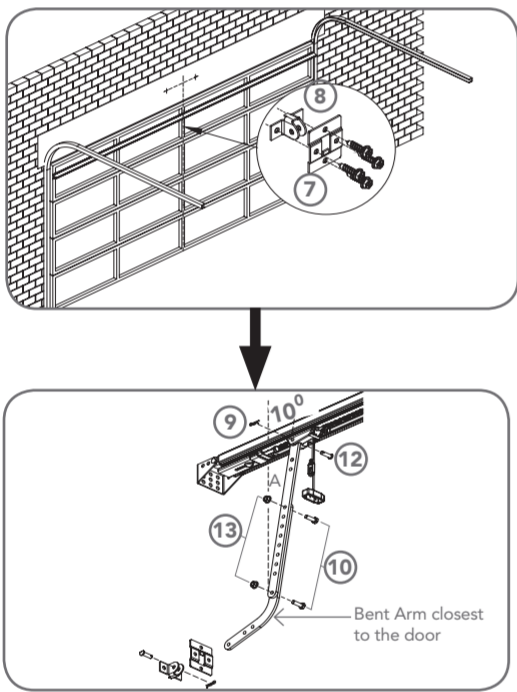

- The door bracket locator ⑦ is placed over the door bracket ⑧, on the door's centre line one-third down the top panel and mounted using M6 or equivalent screws (not supplied).
- STEEL DOORS ONLY:** Bracket can be welded in place.
- NOTE:** If in doubt about the door's strength, reinforcement may be added to the door's frame where necessary. Door damage may occur if the bracket is installed on a panel with insufficient strength. The opener's warranty does not cover damage caused to the door and/or door panels.
- Assemble the bent arm ④ (connecting to the door) to the right side of the straight arm ⑤ (connecting to the shuttle) with bolts ⑩ and nuts ⑪ supplied in the accessory pack. Always use both bent and straight arms.
- Connect the assembled arm to the bracket and the disengaged trolley with clevis ⑫ and snap pins ⑨. The angle "A" must be more than 10°.

CAUTION: Connecting the bent arm the other way around may damage the door. The straight arm should not protrude beyond the heel of the bent arm.

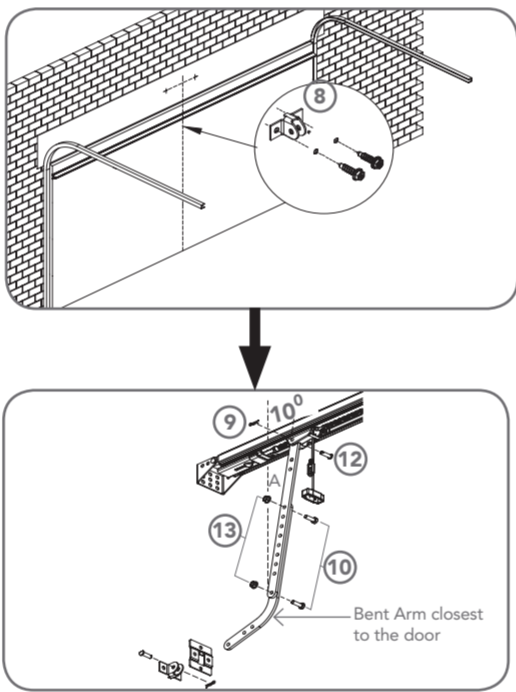

- Mount the door bracket ⑧, on the door's centre line one-third down the top panel and mounted using M6 or equivalent screws (not supplied).
- STEEL DOORS ONLY:** Bracket can be welded in place.
- NOTE:** If in doubt about the door's strength, reinforcement may be added to the door's frame where necessary. Door damage may occur if the bracket is installed on a panel with insufficient strength. The opener's warranty does not cover damage caused to the door and/or door panels.
- Assemble the bent arm ④ (connecting to the door) to the right side of the straight arm ⑤ (connecting to the shuttle) with bolts ⑩ and nuts ⑪ supplied in the accessory pack. Always use both bent and straight arms.
- Connect the assembled arm to the bracket and the disengaged trolley with clevis ⑫ and snap pins ⑨. The angle "A" must be more than 10°.

CAUTION: Connecting the bent arm the other way around may damage the door. The straight arm should not protrude beyond the heel of the bent arm.

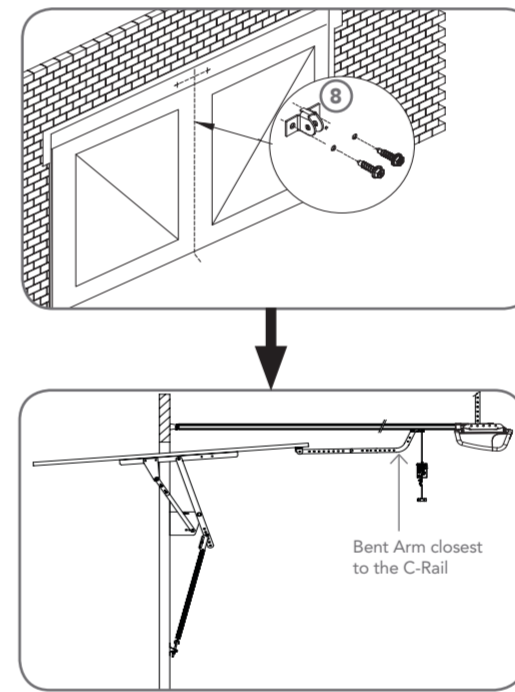

- Mount the door bracket ⑧, on the door's centre line one-third down the top panel and mounted using M6 or equivalent screws (not supplied).
- STEEL DOORS ONLY:** Bracket can be welded in place.
- NOTE:** If in doubt about the door's strength, reinforcement may be added to the door's frame where necessary. Door damage may occur if the bracket is installed on a panel with insufficient strength. The opener's warranty does not cover damage caused to the door and/or door panels.
- Assemble the bent arm ④ and straight arm ⑤ with bolts ⑩ and nuts ⑪ supplied in the accessory pack. Always use both the bent and straight arms.
- Connect the assembled arm to the bracket and the disengaged trolley with clevis ⑫ and snap pins ⑨.
- If installing on a door with a bad wave action, lengthening the arm will assist in reducing this effect.

CAUTION: Connecting the bent arm the other way around may damage the door. The straight arm should not protrude beyond the heel of the bent arm.

Adjusting the Speed Setting

- The default speed of the opener has been set to suit the majority of applications. However, there are three speed modes available if required:-
- Slow - to suit one piece door without tracks
 - Medium (default) - suits majority of applications
 - Fast - to suit some sectional applications
- Proceed to Programming the Opener if the default setting is appropriate. To change the Speed Setting;
The speed settings can only be changed before setting the travel limits. If the opener speed needs to be changed please complete the following process. Pressing the operate button will cycle through all three speed modes.
- To change the speed setting:
- Engage the C-Rail's trolley (attached to the door via the arms) with the chain index by moving the door.
 - If the trolley does not "click" firmly onto the chain index, ensure that the manual release cord is not in the disengaged position by pulling it backwards.
 - Turn on the power to the opener. The CLOSE LIMIT LED will be flashing.
 - Remove the button cover with a blade screwdriver.
 - Press operate button once, twice or three times to select slow, medium or fast speed mode.

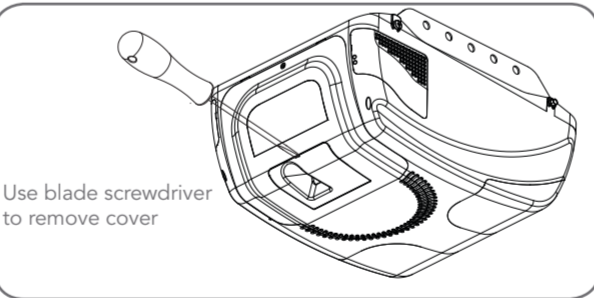

Door Opener Speed Mode	OPEN LED (Green)	CLOSE LED (Red)	Beeper
Medium (Default)	On	On	2 beeps
Fast	On	Off	3 beeps
Slow	Off	On	1 beep

Programming the Opener

- CAUTION:** The OPERATE button will not function until the open and close limit positions are set.
- NOTE:** The door and shuttle must be engaged into the chain index. The door should be open approximately half way.
- Remove the controls cover to access the controls panel using a blade screwdriver. Refit it when setup is completed.
 - Press and hold the MINUS (-) button to start the door closing. Release the button once you have reached your desired closed limit position.
 - Press the LIMIT SET button. This action will store the close limit position into memory.
 - Press and hold the PLUS (+) button to start the door opening. Release the button once you have reached your desired open limit position.
 - Read the WARNING below.
 - Press the LIMIT SET button to store into memory the open limit position. The door will now automatically close to its limit position then fully open to calculate the Safety Obstruction Forces. Take note of **THE ABOVE WARNING!** The opener can now be operated via the OPERATE button.

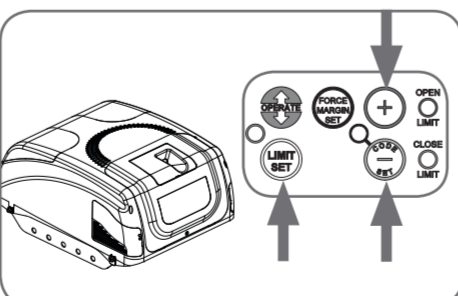

Resetting the Door Limit Positions

- To enter new limit positions the existing settings must be deleted as follows:
- Press and hold the LIMIT SET button for six (6) seconds, until you hear three beeps and the CLOSE LIMIT LED starts to flash.
 - Release the button.
 - Follow Programming the Opener steps to set new limit positions.
- ## Setting the PET Mode position
- When activated, PET mode drives the door to the preset position from the close position.
- Drive and stop the door at the desired PET mode open position by pressing the transmitter button coded for Open/ Stop/Close operation.
 - Press and hold the PLUS (+) button on the opener for six (6) seconds until the OPEN and CLOSE LED's are lit to record the new PET position.
 - Release the PLUS (+) button.

Coding Transmitters

- ## Storing the Transmitter Code
- The opener can only operate from transmitters that have been programmed into its receiver. The receiver needs to learn the codes of any transmitter that will be used with the operator. Up to eight (8) codes can be stored in the receiver's memory.
- Press the CODE SET button and release. The CODE SET LED will illuminate to indicate the opener is in Code Learn mode. If a valid code is not stored within 15 seconds the opener will exit Code Learn.
 - Press the transmitter button (one of four) that you want to control the door. The CODE SET LED will begin to flash.
 - Press the same transmitter button again. The CODE SET LED will illuminate for one second and then go out.
 - The transmitter is now coded to operate the door - press the button to test.

- ## Setting the Transmitter to Operate the Courtesy Light
- Press the CODE SET button twice. The CODE SET LED will illuminate and the courtesy light will turn on to indicate that the light code learning is active.
 - Choose a transmitter button not already coded into the receiver. Press this button and the CODE SET LED will begin to flash.
 - Press the same transmitter button again. The CODE SET LED will illuminate for one second and then go out, and the courtesy light will also switch off. This indicates the code has been stored.
 - To activate Vacation Mode, close the garage door and press the coded button transmitter for 5 seconds. The CODE SET LED will illuminate to indicate that the opener is in Vacation Mode.
 - To exit Vacation Mode press the transmitter button momentarily until the CODE SET LED turns off.
- ## Enabling AUX Output
- Press the CODE SET button four (4) times - the CODE SET LED will illuminate and the courtesy light will flash quickly.
 - Press one of the four (4) buttons on the transmitter for two (2) seconds, the CODE SET LED will begin to flash, pause for two (2) seconds, then press the same button again for two (2) seconds. The CODE SET LED will illuminate for one second then go out.
 - Press the transmitter button to test.

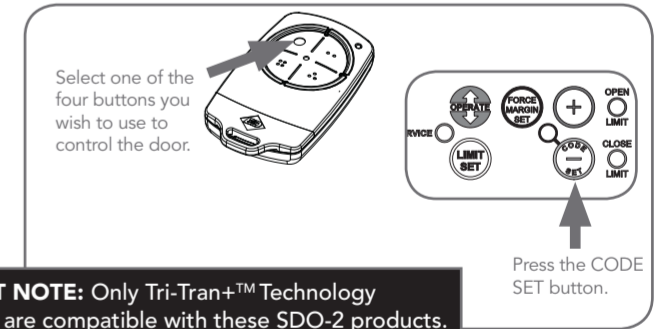

IMPORTANT NOTE: Only Tri-Tran™ Technology Transmitters are compatible with these SDO-2 products.

Setting PET (Pedestrian) Mode

- The PET mode position is set during installation.
- Press the CODE SET button five (5) times - the CODE SET LED will illuminate and the courtesy light will flash quickly (twice per second).
 - Press one of the four (4) buttons on the transmitter for two (2) seconds, the CODE SET LED will begin to flash, pause for two (2) seconds, then press the same button again for two (2) seconds.
 - The CODE SET LED will illuminate for one second and then go out, and the courtesy light will also switch off. This indicates the code has been stored.
 - Press the transmitter button to test.

To Erase Programmed Codes

If the CODE SET button is pressed and held for six (6) seconds the CODE SET LED will blink rapidly for one second to indicate that all programmed codes have been erased.

Installation of the Wall Mounted Transmitter

- Mount the transmitter in a convenient location, yet out of reach of children and at least 1.5m off the ground.
- Make sure the door is visible from this location.
- To set the transmitter codes refer to Storing the transmitter code above.

Remotely Coding Transmitters

- Using this method transmitters can be coded without access to the opener's control panel as long as a pre-coded transmitter is available.
- Take any pre-coded transmitter. Press the button for the function to be duplicated and release.
 - Using a small needle / pen, press and hold firmly for two seconds the middle button, through the Coding Hole.
 - Within ten (10) seconds take the additional transmitter you wish to code. Hold the new transmitter's button for two seconds, pause for two seconds, hold again for two seconds and then release.
 - Wait for ten (10) seconds and then press the new transmitter's button to test.

Proceed to Safety Obstruction Forces